

*greens*IRON 3900

OPERATION, PARTS & SERVICE MANUAL

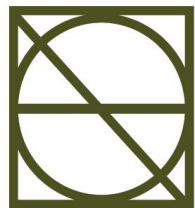

MANUFACTURED BY



woodbay

TURF TECHNOLOGIES

Rev. 3 – 11/26/09

PRESIDENT'S MESSAGE



On behalf of Wood Bay Turf Technologies and your local distributor, we thank you for purchasing the high performance **greensIRON 3900**. **You are rolling in the right direction for smooth and fast greens!**

Introducing a **greensIRON** into the turf maintenance program at your course will provide many important benefits. In the development of the **greensIRON 3900**, our engineers were thinking about the needs of your course. We've met the many challenges and unconventional requirements of turf managers by working with superintendents and their staff. You can be assured the smoothest putting greens, increased green speed, and decreased mowing frequency are all very important benefits received when you iron your greens with Wood Bay's 3900. The **greensIRON 3900** will improve the putting surface after aeration and/or top dressing and allow an increase in mowing heights to reduce turf stress. Meet your expectations with superior equipment manufactured by Wood Bay Turf Technologies.

The **greensIRON** Turf Broom is a very popular attachment for enhancing putting surfaces after top dressing. It will decrease your labor costs and is one of numerous customer suggestions developed into smart design solutions for **greensIRON** owners. The **greensIRON** Turf Ventilator also lets you improve air and water penetration in your greens without any player interruption. We are manufacturers of eco-friendly products. The **greensIRON** light kit allows staff to get that early start and we began offering an electric start option for additional operator convenience.

We urge you to read this manual carefully. The instructions and recommendations for operating the **greensIRON 3900** will help assure the safe and enjoyable use of this equipment.

Thank you for choosing the **greensIRON 3900**.

D. Lyall Adams
President

INTRODUCTION

The purpose of this manual is to provide you with reference information and assistance in setting up, maintaining and operating your *greensIRON 3900* in a safe, effective and efficient manner. It is intended for turf rollers powered with the Hydro-Gear hydrostatic transmission. We expect that this manual will answer most of your questions, but Wood Bay encourages you to contact your local distributor or Wood Bay's Technical Service Center on our toll free line (available in North America at 1-800-661-4942) for further assistance or clarification at any time.

The manual alerts you to safety and environmental considerations, special features of the *greensIRON 3900*, operations, ironing techniques, adjustments, servicing, trouble shooting and replacement parts identification. It also introduces you to the special attachments and accessories that you may obtain to increase the benefits of turf rolling in maintaining and enhancing your greens, both in terms of turf health and putting performance for your golfers. We strive for not only what could be, but what should be in your turf management program.

Please note that the information, illustrations and specifications contained in this manual are based on the latest product information available at the time of printing this manual. Wood Bay Turf Technologies reserves the right to make changes at any time, without notice, in specifications and models and also to discontinue models. The right is also reserved to change any specifications or parts at any time without incurring any obligation to install the same equipment on models manufactured prior to the date of such change.

The illustrations used in this manual may not depict actual models or equipment and are intended as representative views for reference only.

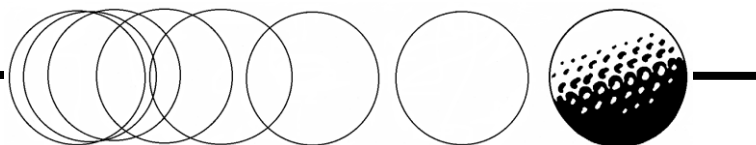

TABLE OF CONTENTS

PRESIDENT'S MESSAGE	1
INTRODUCTION	2
TABLE OF CONTENTS	3
SECTION 1	4
WARNINGS-SAFETY CONSIDERATIONS.....	4
SECTION 2	5
MAJOR COMPONENT DESCRIPTIONS.....	5
FRONT VIEW	5
SIDE VIEW	5
TOP VIEW	5
SECTION 3	6
FEATURES.....	6
SECTION 4	7
ASSEMBLY AND SET UP	7
ASSEMBLY INSTRUCTIONS.....	7
SET UP PROCEDURES.....	8
SECTION 5	10
OPERATION	10
BEFORE STARTING YOUR <i>greensIRON 3900</i> TURF ROLLER.....	10
STARTING HONDA MOTOR.....	10
OPERATOR FAMILIARITY WITH MACHINE.....	11
PEDAL CONTROL	11
STEERING	12
LOADING AND UNLOADING	12
IRONING TECHNIQUES AND PRACTICES.....	13
SECTION 6	14
SERVICING AND MAINTENANCE.....	14
HYDROSTATIC TRANSMISSION and HYDRAULIC MOTOR	14
MONITORING THE HYDROSTATIC TRANSMISSION PERFORMANCE	14
CARE OF THE DRIVE CHAIN.....	15
CLEANING OF STEERING ROLLERS AND TRAILER.....	15
DRIVE ROLLER	15
STEERING ROLLERS AND HANDLE BARS	15
TRAILER.....	15
SEAT	16
PAINTED SURFACES	16
HYDRO-GEAR TRANSMISSION	16
FIRST 20 HOURS.....	16
ENGINE MAINTENANCE.....	17
SECTION 7	18
TROUBLE SHOOTING	18
SECTION 8	21
PARTS LIST AND ILLUSTRATIONS.....	21
SECTION 9	39
WARRANTY	40
FOR LOCAL SALES.....	47

WARNINGS-SAFETY CONSIDERATIONS

PLEASE OBSERVE ALL WARNING STICKERS LOCATED ON THE EQUIPMENT.

WARNING INDICATES A STRONG POSSIBILITY THAT EQUIPMENT DAMAGE OR PERSONAL INJURY COULD OCCUR WITH IMPROPER USE. **REMEMBER SAFETY FIRST!**

- * **WARNING** Ensure that the trailer is attached to the transport vehicle before unloading or loading the *greensIRON*.
- * **WARNING** Keep all person(s) clear when towing unit because the **TRAILER MAY BE WIDER THAN TOW VEHICLE.**
- * **WARNING** Learn how to stop the Honda motor quickly, and understand the operation of all controls. Never permit anyone to operate the *greensIRON* without proper instructions and initial training at slow speeds.
- * **WARNING** Do not over fill the fuel tank. There should be no fuel in the filler neck. If any fuel is spilled, clean it up completely and allow petroleum vapor to dissipate before starting the motor. Refuel in a well-ventilated area with the motor stopped; do not smoke or allow flame or sparks in the area. Gasoline is highly flammable and explosive under certain conditions. Close the filler cap securely.
- * **WARNING** The exhaust muffler becomes hot during operation and remains hot for a period of time after stopping the engine. Be careful not to touch the exhaust muffler while it is hot.
- * **WARNING** Children or passengers must not be allowed to ride on the *greensIRON* or trailer.
- * **WARNING** Be aware of and avoid severe grades and unusual undulations, as well as adjacent sand traps and water features (this also applies to loading and unloading). Ensure paths, gates and bridges can accommodate width of trailer.
- * **WARNING** Start and stop the motor from a seated position when possible, and ensure pedals are in the neutral position to avoid any unexpected movement.
- * **WARNING** Be aware of the local conditions that you are operating under. The *greensIRON* may have less traction on wet turf, and on higher cut turf.
- * **WARNING** Ensure that the motor is shut off prior to servicing any component under the safety guards, deck, transmission, motor coupling, or the motor itself.
- * **WARNING** Wear suitable protective clothing and sunscreen so as to prevent eye damage, hearing impairment and sunburn.
- * **WARNING** Sudden release of the forward clutch pedal will result in the gradual slowing down/ stopping of the *greensIRON*. Engaging the opposite clutch pedal while the *greensIRON* is in motion will result in the sudden or immediate stop of the drive roller and could cause personal injury and possible bruising of the turf. Always train on the equipment at slow speeds.

TO VALIDATE THE *greensIRON* 3900 WARRANTY, COMPLETE THE SAFETY ACKNOWLEDGEMENT AND WARRANTY FORMS PROVIDED AND RETURN TO WOOD BAY TURF TECHNOLOGIES (see Pages 42 and 44).

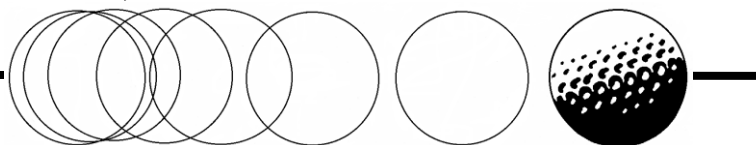

MAJOR COMPONENT DESCRIPTIONS

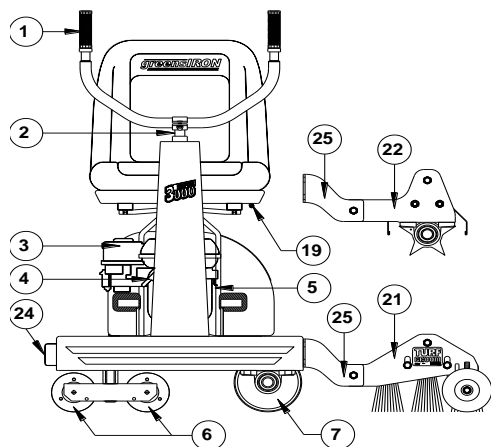

FRONT VIEW

- 1** Soft Hand Grips (each side)
- 2** Handle Bar Adjustment Lever (Not Shown)
- 3** Honda GX160 K1QX 5.5 hp Motor
- 4** Manual Recoil Starter and Hour/RPM Meter
- 5** Engine Switch (ON/OFF) & Oil Alert Light
- 6** Steering Rollers (Galvanized Tapered/Non-Ridging)
- 7** Drive Roller (Super Turf Trac Coating)
- 8** Optional Electric Start (Battery Not Shown)

SIDE VIEW

- 9** High Back Seat c/w Drain Hole
- 10** Steering Column Cowling and Cover
- 11** Transmission Cover
- 12** Drive Chain and Sprocket
- 13** Drive Roller Bearings
- 14** Super Turf Trac covering (Disperses Water and Provides Positive Traction)
- 15** Drive Roller Tapered (Non-Ridging)

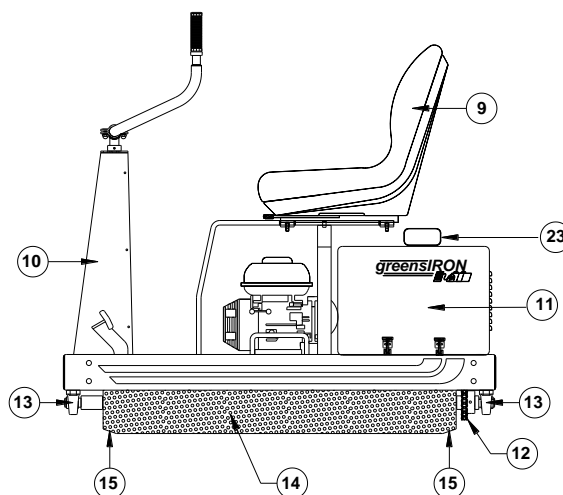

TOP VIEW

- 16** greensIRON - Trailer Locking Latch Bar
- 17** Non-Slip Deck Surface
- 18** Direction Pedal - Right
- 19** Direction Pedal - Left
- 20** Seat Forward/Reverse Adjustment Lever
- 21** Optional Turf Broom Attachment
- 22** Optional Turf Ventilator Attachment
- 23** Optional Lights
- 24** Bumper Pads
- 25** Accessories Attachment Bracket (Not Shown)

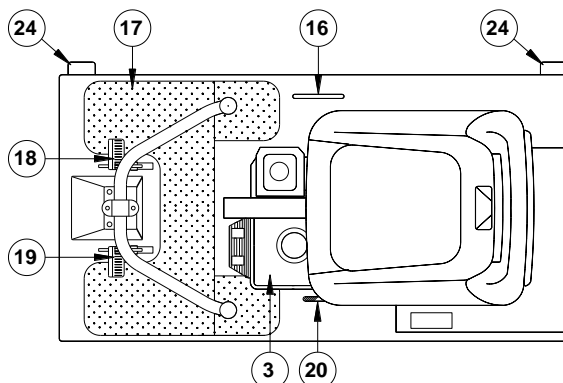

SECTION 3

FEATURES

UNMATMATCHED QUALITY AND COMMITMENT: PERFORMANCE EVERY DAY

- ◆ Precision engineered components in each *greensIRON* produce amazing operator satisfaction from start to finish.
- ◆ Unique and dynamic steering system for straight tracking over flat to undulating greens.
- ◆ High back padded seat with slide adjustment for maximum operator comfort and support.
- ◆ Minimal day to day maintenance requirements combined with the new low torque powerful Hydro-Gear hydrostatic transmission and hydraulic motor. Customers can expect longer life with less maintenance.
- ◆ Machined and tapered galvanized steel steering rollers give both maximum durability and aesthetic appeal.
- ◆ Minimal vibration levels and comfortable seat improves productivity and significantly reduces operator fatigue.
- ◆ The Super Turf Trac drive roller covering provides increased high performance traction when you need it in severe undulating conditions. Produces a soft touch effect for putting. Reduced scuffing on collars.
- ◆ Industrial bearings, with convenient access to grease ports.
- ◆ Powerful and economical to operate Honda GX160 UTQX26 5.5 hp engine.
- ◆ Multi-purpose transport trailer complete with extra long tailgate ramp is designed for fast, trouble-free loading and unloading. Highest quality rust protection liner throughout trailer.
- ◆ Convenient and easy to locate main drive components including: hydrostatic pump oil reservoir, drive sprockets, drive coupler, hydrostatic transmission, hydraulic motor, Honda motor and drive chain adjustments.
- ◆ Factory installed oil drain hose and tap for easy and efficient servicing of Honda motor.
- ◆ Optional 25-watt magneto lighting system for “night time” illumination.
- ◆ Optional Turf Broom attachment will create a perfect finish to greens following top dressing.
- ◆ Optional Turf Ventilator available when fast and efficient aeration is required on greens and tees.
- ◆ Optional, side-loading trailer (special order) for courses with narrow pathways, gates and bridges.
- ◆ Optional electric Honda motor start for extra convenience.
- ◆ Limited one year warranty on parts and labor.

Owning a greensIRON 3900 is rolling in the right direction!

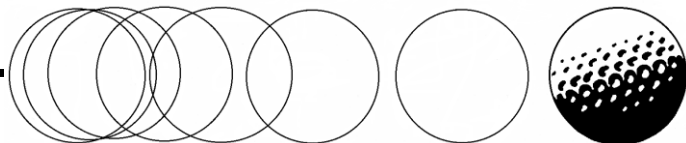

ASSEMBLY AND SET UP

ASSEMBLY INSTRUCTIONS

1. Remove all packaging and crating materials except the bottom pallet.
2. Remove and unpack fenders (2), wheel hub and axle assemblies (2), tow bar for trailer (1), and seat for the *greensIRON 3900* turf roller.
3. If the optional Turf Broom and/or Turf Ventilator attachment kits are included in your order (see packing slip and notations on crate), remove, and assemble them separately. The Turf Ventilator is assembled, and the Turf Broom has been assembled in part, at the manufacturing plant prior to shipping. The hardware package and instructions are enclosed. The right and left support brackets can stay permanently bolted to the side of the *greensIRON*.
4. Located under the transmission cover is the hardware (bolt package) and operations manuals (including the *greensIRON 3900*, Honda engine, Hydro-Gear hydrostatic transmission and hydraulic motor) with their warranty registration forms.
5. Remove the two locking pins and lower tailgate down to the floor surface. Place cardboard or packing material between the floor and tail gate to prevent scratching/paint damage.
6. Lift the roller-locking pin at the front of the trailer, releasing the *greensIRON 3900*, and insert it back in the holder slot. Slowly roll the *greensIRON* out of the trailer box and down the ramp. Remove the pallet from under the trailer.
7. Raise the tail gate and insert both locking pins. Tip the trailer box to rest on the tail gate for the next part of the assembly. Install the trailer fenders with eight (8) 3/8" x 1" bolts, nuts and washers prior to installing axels and wheels.
8. Insert the axle tube assemblies (2) into the sides of the trailer box. **Ensure that hub is positioned above the axle tube to maintain a low trailer elevation.** Attach securely with four (4) of the 1/2" x 2 3/4" bolts, washers and nuts (nuts facing the rear). If it is difficult to push the bolts through the holes, try switching the axle tubes from one side to the other.
9. Mount wheels to the hubs with wheel lugs provided. The bearings have been serviced and packed, and are ready for operation. Check the tire pressure. Since the trailer has no springs, eight to ten (8-10) psi is recommended for most conditions.
10. Secure the trailer tow bar to the trailer box, using two (2) of the 1/2" x 2 3/4" bolts, washers and nuts. **Ensure that when installed the tow bar curves upwards at the towing machine.** Tip the trailer back down on its wheels. The trailer is now ready for use. **Note:** the tow bar should always be firmly connected to a towing machine before attempting to reload the *greensIRON 3900* turf roller. When connected to the towing unit, the bar and trailer box should be parallel with the ground.

SECTION 4 (con't)

11. **Loosen the handle bar clamp; turn the handle bars up so the hand grips are in a vertical position.** Tighten adjustment lever. **Note:** The position of the handle bars may be adjusted to meet operator preference using the handle bar lever; caution: do not wear the knurling on the handle bar clamp.
12. Install the seat with its slide frame onto the turf roller seat brackets, and secure with the four (4) 5/16" nuts and lock washers provided. Tilt the seat forward prior to opening transmission cover.

NOTE: *greensIRON 3900 is shipped without motor and transmission lubricants, or fuel.*

13. Refer to the enclosed Honda motor owner's manual; fill the motor to the **correct level** with the recommended lubricant. Use high detergent, premium quality oil for the motor. The Honda manual recommends SAE 10W 30 for general, all temperature use.
14. Fill the fuel tank with unleaded fuel. **Do not overfill.**
15. Pour approximately three (3) liters of Mobil 1 5W40/50 synthetic oil into the Hydro-Gear transmission tank. Do not fill over/above the sight glass.
16. Lubricate the drive chain as required – see Maintenance Schedule.
17. Grease as required the steering roller pivot (1) and drive roller bearings (2).

Now that your *greensIRON 3900* is completely assembled, refer to the "Set Up Procedures" before moving onto the green.

SET UP PROCEDURES

1. Your *greensIRON 3900* does not have a throttle cable. Prior to normal operations, set the Honda motor throttle lever for preferred RPMs. Initially, RPMs should be set low until the operator is familiar with the operations of the machine. Once training and familiarization with the equipment is complete, RPM's may be increased (maximum 3650) for faster *greensIRON* speeds. See RPM digital tach located on motor.
2. The drive chain tension has been preset at the factory. During assembly the *greensIRON 3900* may require minor adjustment. To make an adjustment, loosen the ½ inch nut on the idler sprocket and slide the sprocket in the direction required to ensure a ¼ inch deflection at the center of the chain. It will feel quite tight. Ensure that the chain is lubricated regularly.
3. All steering end roller bearings come pre-packed with grease. After one months operation apply additional grease sparingly.

Recheck all nuts, screws and set screws to ensure that none have loosened during transport.

Your *greensIRON 3900* is now ready to operate.

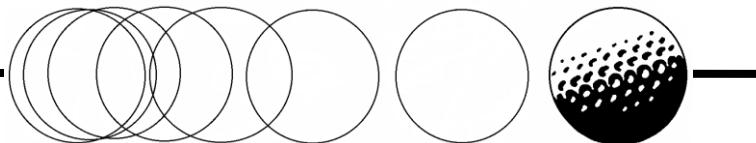

SECTION 4 (con't)

Comment

We trust that these instructions have enabled you to assemble and get to know your *greensIRON 3900* turf roller. If you have suggestions, questions, or wish to comment on the instructions, please let us know; in North America telephone 1-800-661-4942 or 780-468-4378, e-mail at info@woodbayturftech.com or fax comments to 780-468-0059. We appreciate your assistance and thank you for choosing one of Wood Bay's innovative products, the greensIRON 3900.

**For further information contact your local distributor
or the manufacturer Wood Bay Turf Technologies, 1-800-661-4942.**

www.woodbayturftech.com

OPERATION

BEFORE STARTING YOUR *greensIRON* 3900 TURF ROLLER

- ✓ Refer to your Honda motor, Hydro-Gear hydrostatic transmission, and the hydraulic motor owner's manuals for start up and break-in recommendations.
- ✓ Check oil levels in both Honda motor and Hydro-Gear oil reservoir.
- ✓ Check fuel level (unleaded fuel is recommended).
- ✓ Check drive chain adjustment. Chain may require tightening after initial operation on golf course. Lubricate chain frequently.
- ✓ Check on both sides of the *greensIRON* prior to operation to ensure there are no obstructions that could tear the Super Turf Trac drive roller covering.

STARTING HONDA MOTOR

- ✓ Turn the fuel switch to the ON position.
- ✓ Turn the motor switch to the ON position.
- ✓ Engage the choke switch if required.
- ✓ Pull the starter recoil handle (it is recommended that the operator start the engine while seated on the *greensIRON*). Ensure both foot pedals are in the neutral position.
- ✓ Once the motor is running, shut off the choke switch and adjust throttle speed.
- ✓ Set the throttle speed manually with engine throttle lever.
- ✓ To stop motor, turn ON/OFF switch to the OFF position, and close OFF fuel switch.

- 1** Fuel switch
- 2** Choke
- 3** Manual throttle lever
- 4** Engine switch
- 5** Pull start handle
- 6** Hour/RPM meter (not shown)

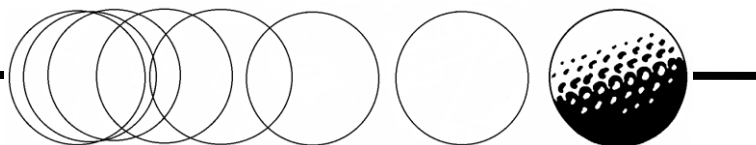
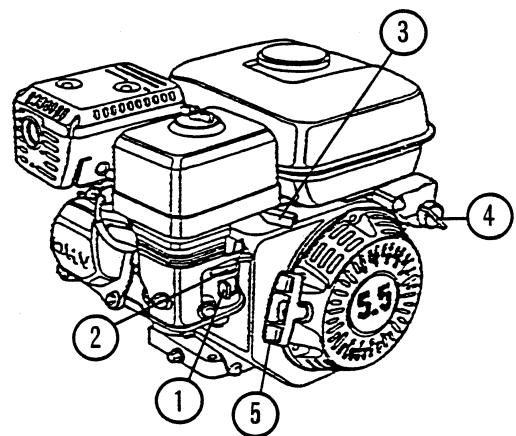

OPERATOR FAMILIARITY WITH MACHINE

- When initially operating a *greensIRON* with the Hydro-Gear hydrostatic transmission, it is important to get comfortable with the controls and the "feel" of the smooth operation of this turf roller. Operator training should be conducted at a relatively low-speed on large level greens. Since the speed of the motor determines the amount of torque delivered through the hydrostatic transmission, Wood Bay recommends that all operators set the engine speed to less than one-half throttle until they are very comfortable with both the steering handle bars and the left and right directional foot pedals. A low throttle setting will limit the maximum speed at which the turf roller will travel in a given direction when the pedal is fully depressed. When the operator has become accomplished with the *greensIRON* controls, the throttle can be set fully open to both increase speed, and efficiency in "ironing" your greens.
- **WARNING:** Do not jam your foot down hard on a directional pedal to start the *greensIRON* moving. This action could suddenly engage the drive roller causing it to spin and potentially bruise the turf. Smooth, steady starts and stops of the *greensIRON*, effected through even foot pedal pressure, will produce the best turf ironing results for the golf course.

PEDAL CONTROL

- **DO NOT DEPRESS BOTH PEDALS AT THE SAME TIME**, as clutch linkage damage will occur.
- Depress the pedal smoothly and steadily for the desired direction of travel; left pedal for left travel; right pedal for right travel (reference to left and right side of the *greensIRON* is determined while seated on the unit looking forward). To increase ground speed, press the pedal down further.
- When slowing or stopping the *greensIRON 3900*, ease back on the foot pedal.
- For an **EMERGENCY** stop, release the direction-controlling foot pedal and apply light pressure to the opposite foot pedal. If the engine does not stop, turn the engine switch to "Off". **DO NOT DRAG YOUR FEET ON THE GROUND AS A BRAKING DEVICE.**
- **ABRUPT EMERGENCY STOPS MAY RESULT IN BRUISING OF THE TURF.**
- The *greensIRON* will remain in a stationary position when pedals are in the neutral position.

- 1 Left drive direction control pedal
- 2 Right drive direction control pedal
- 3 Aluminum checkered traction plate
- 4 Engine switch (ON/OFF) and oil alert
- 5 Pull starter handle
- 6 Fuel switch and choke lever
- 7 Roller-trailer locking latch bar

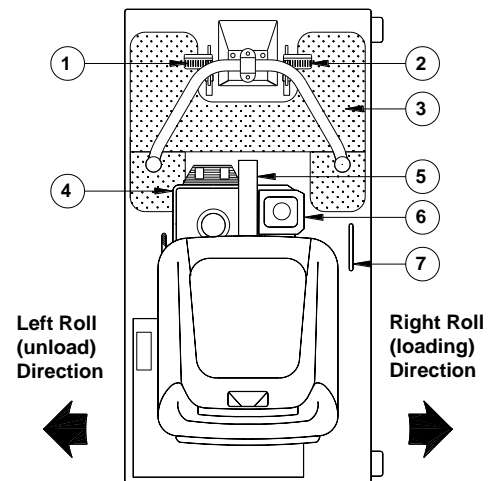

STEERING

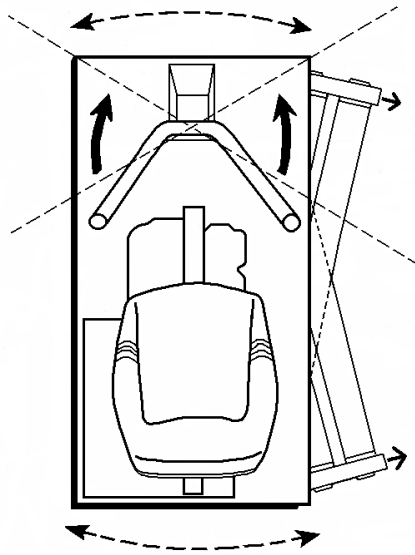

Pushing the left handle bar away from the operator will pivot the front of the steering rollers out. This will cause the *greensIRON* to commence a turn to the right when rolling in that direction, or to the left when rolling in that direction.

Pushing the right handle bar away from the operator will pivot the back of the steering rollers out. This will cause the *greensIRON* to commence a turn to the left when rolling to the right, or to the right when rolling to the left.

Avoid over steering to prevent the possibility of turf damage. This is especially true when the *greensIRON* is in a stationary position.

LOADING AND UNLOADING

- Ensure the transport trailer is securely attached to the transport vehicle and the *greensIRON* locking latch is engaged before transporting equipment to the green.
- Transport the *greensIRON* to the green to be ironed. Back the trailer unit towards the green so that when the tail gate is lowered it will rest evenly on the edge of the collar. **DO NOT BACK THE TRAILER ON TO THE GREEN.**
- For side-loading units, transport the *greensIRON* to the collar of the green to be ironed, and stop at a distance where the gate can be lowered to rest evenly at the collar edge. **DO NOT DRIVE TRAILER ON TO THE GREEN.**
- Start the motor, release the *greensIRON* locking latch, depress the left pedal and drive the unit down the ramp on to the green. **FOR SAFETY REASONS DO NOT OVER ACCELERATE WHEN LOADING OR UNLOADING.**
- To reload the unit, reverse the above procedures aligning loading markings on the *greensIRON* with centerline on the tail gate. The *greensIRON* can only be loaded and secured to the trailer from the operator's right hand side. The non-slip coating on the tail gate ramp and trailer deck provides excellent traction when loading. Line up the *greensIRON* with the trailer and drive up the tail gate. Do not over accelerate, and stop gently. Once the *greensIRON* is in place on the trailer, insert the locking pin to prevent roller movement during transport. Shut off the motor and fuel switches, and latch both sides of the tail gate.

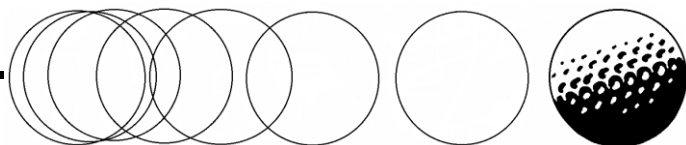
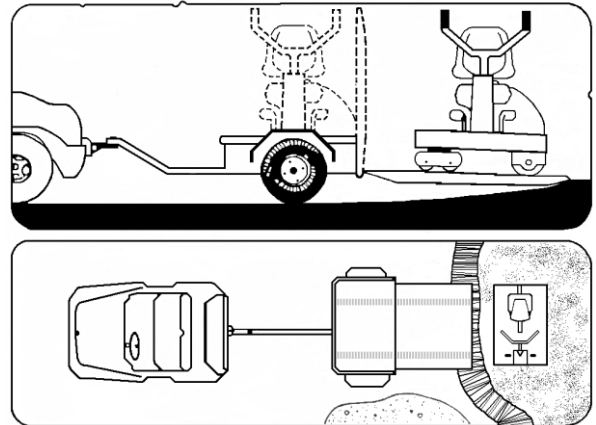

IRONING TECHNIQUES AND PRACTICES

DO NOT REFUEL *greensIRON* WHILE ON THE GREEN.

- **DO NOT DRIVE TRAILER ON GREENS OR TEES.**
- Ensure transport trailer is always securely attached to the transport vehicle during loading and unloading.
- **DO NOT LEAVE *greensIRON* SITTING ON THE GREEN SURFACE FOR LENGTHY PERIODS OF TIME.**
- Always have the *greensIRON* in motion when turning sharply.
- The most efficient ironing pattern likely will be to travel across a steep sloping green at a slight angle. The ironing pattern should allow the operator to face oncoming play from down the fairway.
- Maximum ironing performance is gained by keeping the left side of the *greensIRON* on the downhill side of a slope.
- Prevent creasing, marking or ridging. Adjust the ironing pattern to accommodate any sharp undulations in green surface. Steer the roller into a steep slope along the periphery of a green, minimizing the chance of creasing on the low side of the *greensIRON*.
- Be aware of bunkers, steep drops or water features adjacent to greens.
- The preferred ironing effect for putting is obtained at a travel speed of 1000 sq. ft. per min. (5-7 mph).
- Iron green in the direction that allows the Turf Broom to contact top dressing before the rollers.
- For superior results, drive *greensIRON* with the Turf Ventilator in the forward position.
- For new operators, driving the *greensIRON* toward the direction of the sun will help travelling in straight lines and increase efficiency.
- On large rectangular greens, ironing the green over the longest direction will increase efficiency.
- For TV golf events and other important tournaments make two passes around the periphery of the green. Start turning the *greensIRON* early when both going down a slope and turning at the same time.
- Should a crease(s) occur when operating in low, wet areas of a green, iron the green while travelling in the opposite direction and this will remove strip marks.

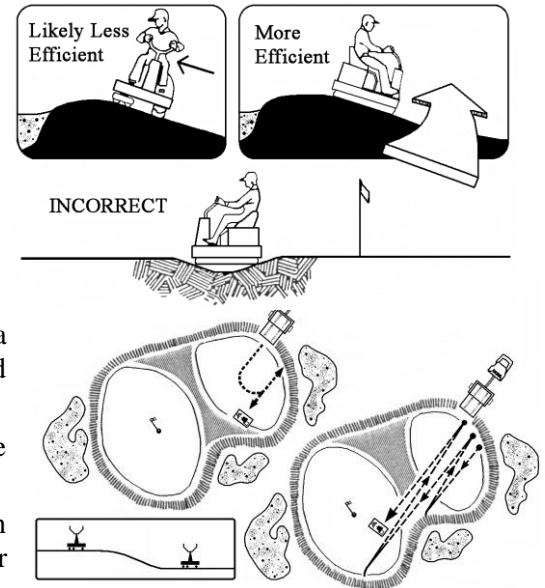

SERVICING AND MAINTENANCE

PRIOR TO UNDERTAKING MAINTENANCE WORK ON YOUR *greensIRON 3900*, SHUT OFF MOTOR.

CAUTION: GASOLINE AND/OR OIL SPILLED OR TRACKED ON TO TURF MAY CAUSE SEVERE DAMAGE.

HYDROSTATIC TRANSMISSION and HYDRAULIC MOTOR

- Refer to your Hydro-Gear hydrostatic and hydraulic motor transmission owner's manuals.
- The Hydro-Gear hydrostatic transmission provides a smooth, powerful and quiet operation. It has been checked and adjusted at the factory to ensure it performs effectively, and that the clutch pedals return to their neutral (i.e., full stop) position when released. **Add approximately three (3) liters of Mobil 1 5W40/50 synthetic oil to the reservoir. Change oil and filter after 100 hours and every 400 hours or annually thereafter.**

MONITORING THE HYDROSTATIC TRANSMISSION PERFORMANCE

Monitor closely the cleanliness of the fan and cooling fins. The transmission may be cleaned with a pressure washer, but **the input and output shaft seals are never to be sprayed directly.**

- Direct pressure wash spraying can damage the seals. Such damage will not be covered under warranty.
- Check temperature and oil levels on reservoir site gauge.
- **Performing regularly scheduled maintenance will keep your *greensIRON* running in top condition.**

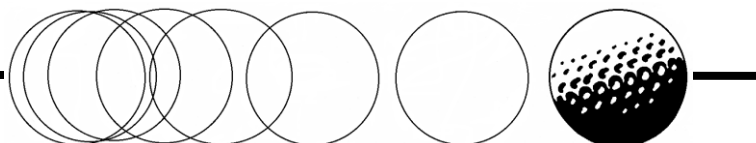

CARE OF THE DRIVE CHAIN

- The drive chain should be re-tensioned and lubricated regularly. Lubricate chain before or after every operation with a spray-on chain lube - lubricating chain regularly will extend life of the chain.
- The chain should have a 3/8" to 1/2" deflection on the side opposite to idler sprocket, under normal operating conditions.
- Should the chain become too loose or too tight, loosen the axle bolt on the idler sprocket and then adjust the idler sprocket as needed to increase or reduce the chain tension. Tighten axle bolts.
- If it is no longer possible to tighten the chain as needed by adjusting the idler sprocket, remove a half link or a full link to shorten the chain. The chain should then be adjusted to the preferred tension.
- Regular applications of a spray-on chain lube will ensure the chain does not become dry and will avoid the possibility of oil or grease contamination on the turf.
- If the chain is allowed to become dry, it will cause the chain to wear and/or break prematurely.

CLEANING OF STEERING ROLLERS AND TRAILER

- Tilt the *greensIRON* down on the drive roller side and remove sand, thatch and other debris on the steering rollers and undercarriage with a pressure hose. Wash the sand and grass material from the trailer while empty. Keeping the trailer clean will help extend the life of the traction surface on the drive roller and enhance the appearance and longevity from the tough abrasion. The liners are great looking with a fine textured finish.

DRIVE ROLLER

- Inspect the drive roller for any dirt or grass clippings and clean thoroughly prior to going on green. Clean with a high powered hose.
- Using a lithium II or non high-temp grease, lubricate both bearings every 20 hours of operation.

STEERING ROLLERS AND HANDLE BARS

- Inspect the rollers for any dirt or grass clippings and clean them prior to traveling on the green.
- Using a lithium II or non high-temp grease, lubricate bearings every 50 hours of use.
- Check periodically for correct steering roller/handle bar alignment.
- Steering rollers must be aligned parallel with the right deck edge. The handle bar in driving position must be at right angles (90°) to the steering rollers. The handle bar alignment can be adjusted by increasing or decreasing the length of the steering rod arm connector assembly, located under the deck. To make an adjustment in the handle bar alignment requires disconnecting at least one rod end, releasing the jam nut, and turning the rod end toward or away from the other rod end on the connector assembly.

TRAILER

- Using lithium II or non-high temperature grease, lubricate the two wheel bearings annually.
- Check tire pressure prior to use. Tire pressure should be kept between 8 - 10 psi.

SECTION 6 (con't)

SEAT

- Use soap and water to keep the seat clean as needed and apply a vinyl protector only, prior to seasonal storage.

PAINTED SURFACES

- Wash with soapy water and a soft cloth. Pressure washing is not recommended. For further protection, an application of wax every month is recommended to maintain an attractive finish.

HYDRO-GEAR TRANSMISSION

- It is important to keep the veins (vents) of the transmission clear of dust and debris to ensure adequate cooling.

FIRST 20 HOURS

- After the first 20 hours of operation, check and tighten, as needed, the linkage of the foot pedals, drive chain, wheel bolts and motor mounts. Also check and tighten as needed all key ways and set screws. This procedure should be conducted every 50 hours thereafter. Check and ensure the steering handle bar clamp bolts remain tight to ensure the gnarling is not damaged.

- **KEEP AN UPDATED RECORD OF THE MAINTENANCE ON YOUR *greensIRON 3900*.**

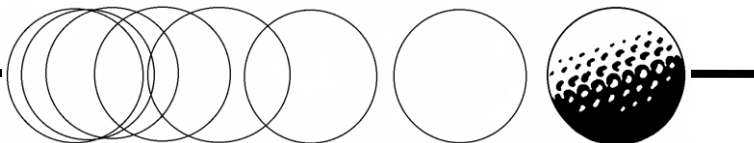

ENGINE MAINTENANCE

Oil

- Check oil level prior to each use.
- Change oil after first 20 hours use and then every 100 hours thereafter.

Reduction Case Oil

- Check oil level prior to each operation.
- Change oil after first 20 hours of use and then every 100 hours thereafter.

Air Filter

- Check prior to each use.
- Clean every 50 hours.
- Replace every year or 300 hours.

Sediment Cup

- Clean every 100 hours.

Spark Plug

- Replace every year or 300 hours.

Fuel Tank and Filter

- Clean every 100 hours.

Refer to separate Honda Engine Owner Manual for specific parts and any other inquiries.

MAINTENANCE SCHEDULE

The *greensIRON 3900* has been equipped with a Tiny Tach hour meter to aid you in maintaining your unit in top condition.

	Each Use	20 Hours	50 Hours	100 Hours	400 Hours	Annually or Prior to Storage
Chains – lubricate	✓					✓
Chains – check tension	✓					
Transmission Reservoir	✓					Change
Hydrostatic Transmission Filter				Change	Change	Change
Rollers – wash/rinse	✓					
Drive Roller – grease bearings		✓				
Steering Roller – grease			✓			
Trailer – grease						✓
Trailer – tire pressure	✓					
Check & tighten the linkage of the foot pedals, fan belt, drive chain, wheel bolts and motor mounts. Check & tighten as needed all keyways and set screws.		✓	✓			
Honda Motor						
Oil	✓	Change		Change		Change
Air filter	✓		Clean			Replace
Reduction Oil Case		Change				
Sediment Cup				Clean		
Spark Plug						Replace
Fuel Tank and Filter				Clean		

TROUBLE SHOOTING

TROUBLE SHOOTING		
SYMPTOM	PROBABLE CAUSE	SOLUTION
Honda motor runs rough.	Choke on. Dirty air filter. Intermittent spark. Improper fuel mixture.	Switch off choke. Clean or replace filter. Clean or replace spark plug. Readjust—see Honda motor manual.
Honda motor cuts out when changing throttle speed.	Oil level low. Fuel level low.	Fill to correct level—see Honda manual. Fill fuel tank.
No movement left or right when pedals are depressed.	Chain is broken.	Replace chain. Adjust tension until desired movement is obtained.
Jerky motion or chain is jumping.	Not enough tension in chain.	Adjust chain tension as explained in Section 5.
Pedal movement is either too free or is difficult to depress.	Tension on nylock nuts for the linkage arms may need adjustment.	Adjust tension on nylock nuts until a comfortable pedal motion is obtained.
Rattling, grinding type of noise from under deck when turf roller is moving.	Chain may be loose. A steering bearing may be failing. Bolts may be loose on moving parts.	If chain is rubbing deck, ensure it is tightened and properly aligned. Lift unit and hand turn rollers to check for noise; grease and/or replace bearings as needed. Check and tighten bolts as needed on: <ul style="list-style-type: none"> • Drive roller pillow blocks • Pedal linkages • Steering roller end bolts/housings • Stopper bolts on top of steering frame
Roller continues traveling after release of pedals to neutral position.	The connection to rocker arm needs adjustment to balance the return distance for both sides.	See Section 5, adjusting for roller creep
Transmission may over heat and feel sluggish, going both left and right to operator.	Transmission oil and filter have not been changed.	Change filter and oil.

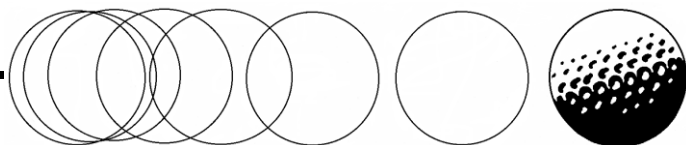

TROUBLE SHOOTING		
SYMPTOM	PROBABLE CAUSE	SOLUTION
With pedal depressed and throttle open, roller needs to be pushed to start moving.	<ul style="list-style-type: none"> • Low oil in reservoir • Failure of Hydrostatic motor or pump 	<ul style="list-style-type: none"> • Fill to proper oil level • Change Hydrostatic pump or motor
Transmission is running extra hot, shortly after starting it up.	<ul style="list-style-type: none"> • Low oil • Filter needs to be changed due to poor oil flow 	<ul style="list-style-type: none"> • Fill to proper oil level • Change filter

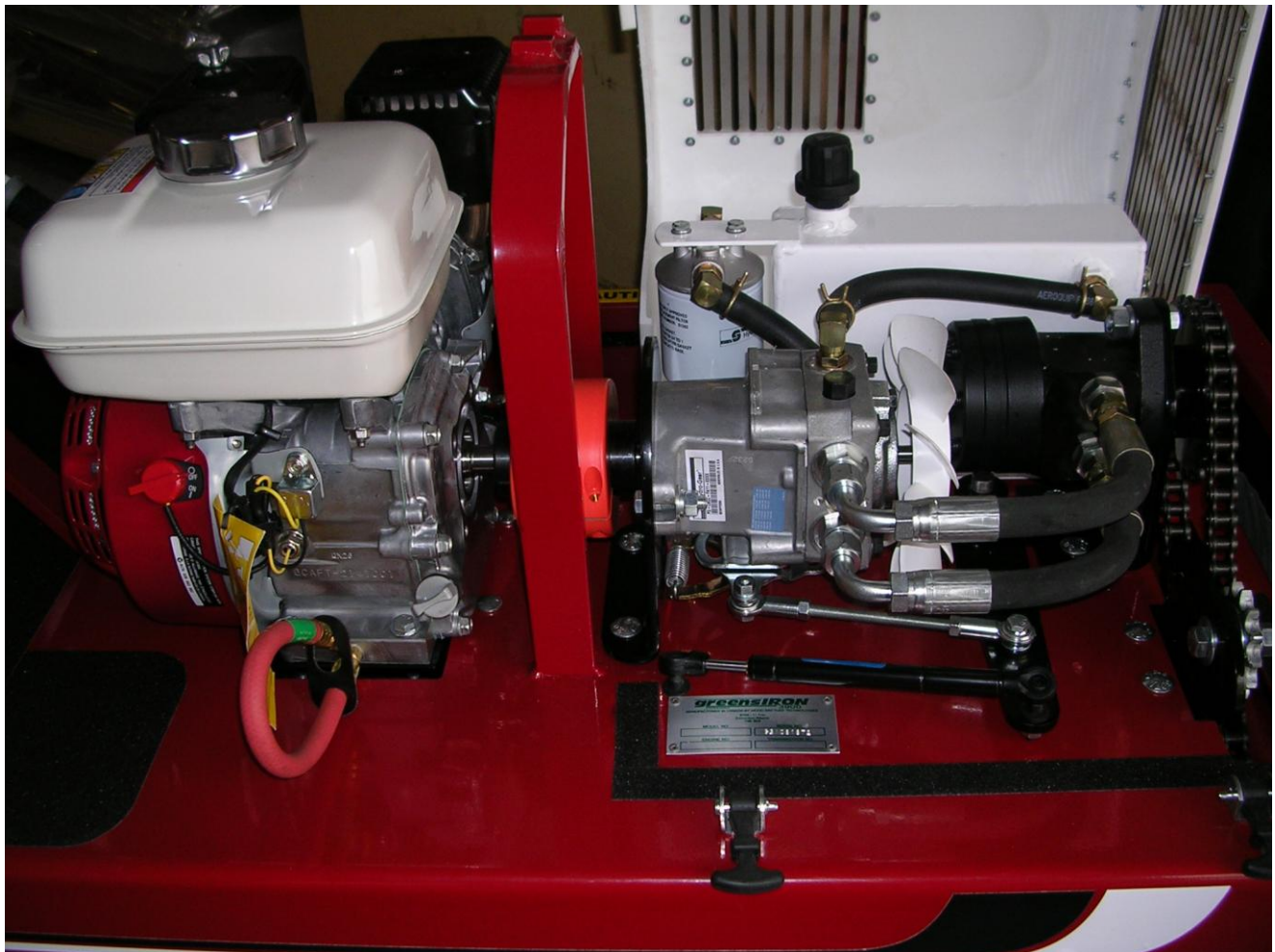

greensIRON Left Side View: Honda Motor and Hydro-Gear Pump



greensIRON Pump Reservoir and Filter

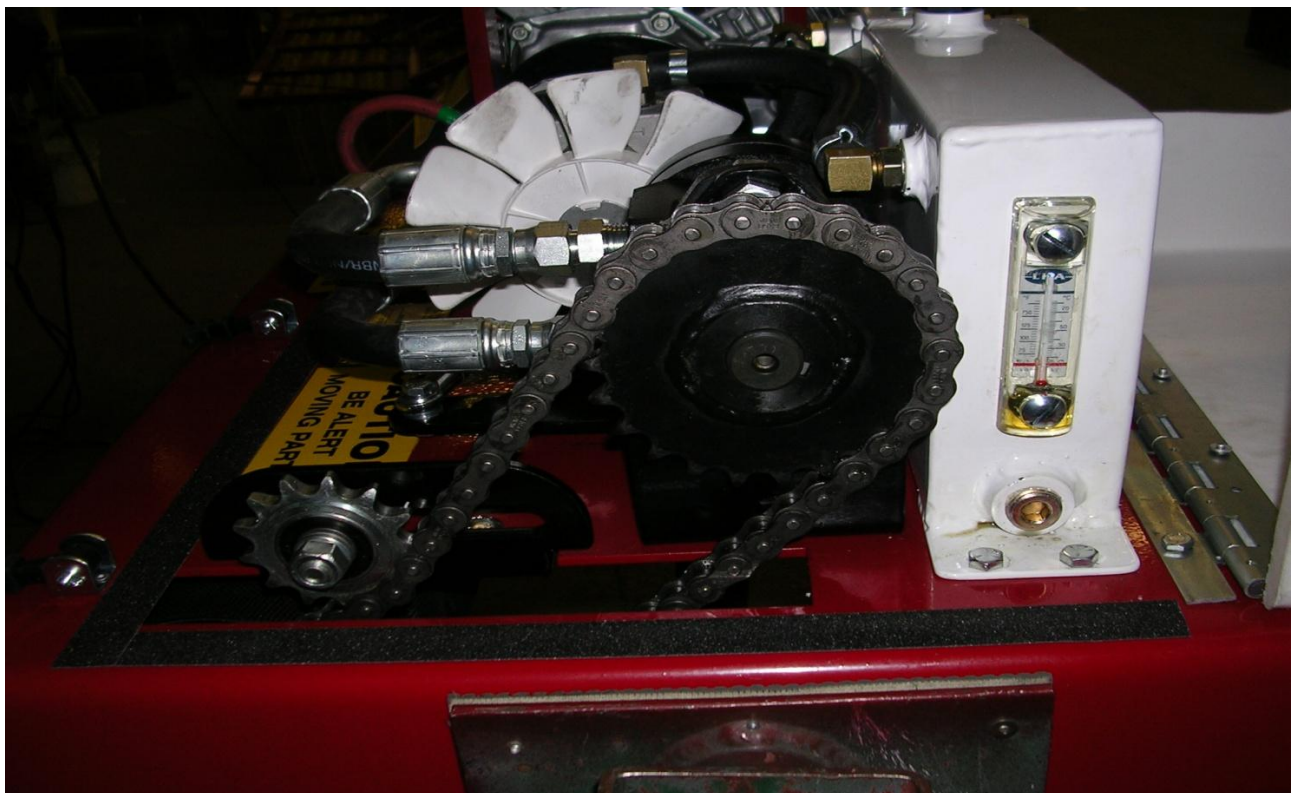

greensIRON Real View: Drive Sprocket, Chain and Pump Reservoir

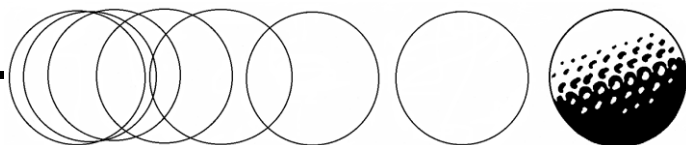

SECTION 8
PARTS LIST AND ILLUSTRATIONS

Clutch Components - Section K

Item	Description	Quantity	Part #
1.	Pedal Pads	2	39 K02 100
2.	Clutch Pedal - Left	1	39 K01 101
3.	Clutch Pedal - Right	1	39 K01 102
4.	Clutch Pedal Bushing	2	39 K01 103
5.	Foot Pedal Linkage	2	39 K01 104
6.	Rod End (3/8" NF - Female RH)	2	39 Y02 183
7.	Rod End (3/8" NF - Female LH)	2	39 Y02 184
8.	Jam Nut (3/8" NF RH)	2	39 Y02 185
9.	Jam Nut (3/8" NF LH)	2	39 Y02 186
10.	Transmission Rocker Arm (welded with #11)	1	39 K01 105
11.	Engagement Arm Connecting Shaft (welded with #10)	1	39 K01 106
12.	Snap Ring (5/8")	1	39 K02 107
13.	Key (3/16" x 1 1/4")	1	39 Y02 187
14.	Bearing and Housing (2 hole - 5/8")	2	39 K02 108
15.	Clutch Pedal Assembly – Left Checkered (no pad) (serial # G3I102091 ongoing – not shown)	1	39 K01 270
16.	Clutch Pedal Assembly – Right Checkered (no pad) (serial # G3I102091 ongoing – not shown)	1	39 K01 271

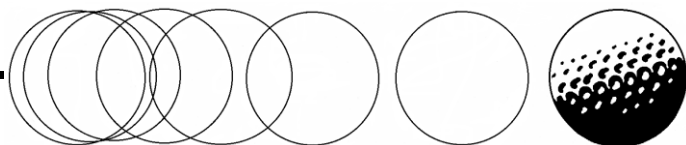
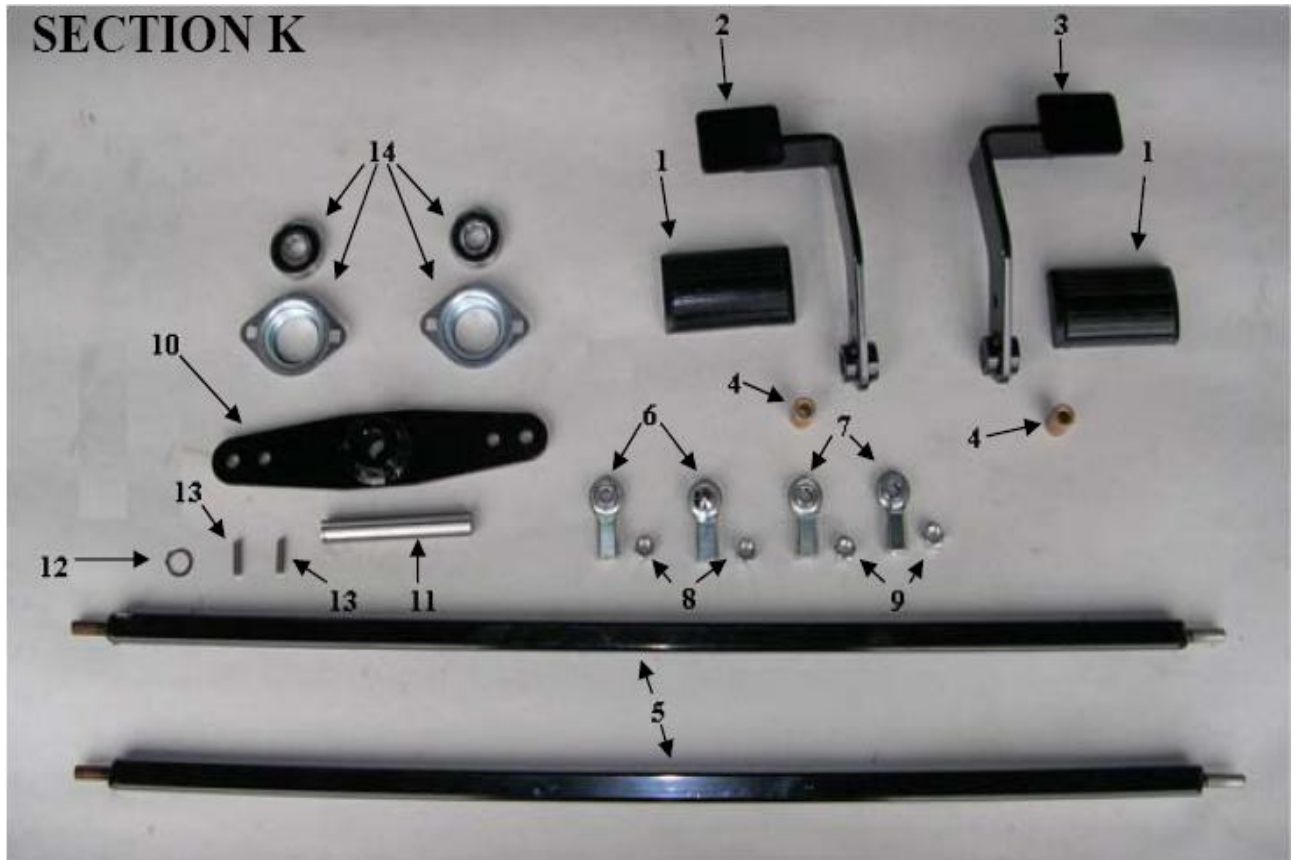

Body Components - Section O

Item	Description	Quantity	Part #
1.	Deck	1	39 001 109
2.	Serial Number Plate (under cowling)	1	39 001 110
3.	Decal Package: Caution	1 set	39 001 111
4.	Decal Package: Identification	1 set	39 001 112
5.	Decal Package: Striping	1 set	39 001 113
6.	Non-Skid Deck Surface	1	39 001 114
7.	Steering Column Cover and Screws (6) (Not Shown)	1	39 001 115
8.	Seat (not shown)	1	39 002 116
9.	Rubber Bumper/Scuff Pad	2	39 002 117
10.	Aluminum Traction Plate	1	39 001 272

SECTION O

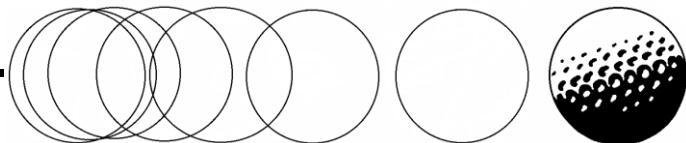

SECTION 8 (con't)

Steering Column Components - Section P

Item	Description	Quantity	Part #
1.	Handle Bar	1	39 P01 118
2.	Steering Hand Grips	2	39 P02 119
3.	Steering Shaft	1	39 P01 120
4.	Handle Bar Clamp	1	39 P01 121
5.	Handle Bar Adjustment Lever	1	39 P02 122
6.	Steering Arm for Under Deck (welded)	1	39 P01 123
7.	Steering Rod Arm (3/8" x 4 1/4" NF)	1	39 P01 124
8.	Rod End (3/8" female NF)	2	39 Y02 183
9.	Jam Nut (3/8" NF)	1	39 Y02 185
10.	Bearing and Housing (4-bolt 1.0")	1	39 P02 125
11.	Bearing and Housing (2-bolt 1.0")	1	39 P02 126
12.	Key (1/4" x 1/4" x 1.0")	1	39 P02 127
13.	Bolt (3/8" x 1 1/2" NC)	4	39 Z02 193
14.	Flat Washer (3/8")	8	39 Z02 195
15.	Lock Washer (3/8")	8	39 Z02 196
16.	Nut (3/8" NC)	6	39 Z02 197
17.	Carriage Bolt (3/8" x 1 1/2" NC)	2	39 Z02 198
18.	Bolt (3/8" x 1 1/4" NC)	2	39 Z02 194
19.	Carriage Bolt (5/16" x 1" NC)	2	39 Z02 208
20.	Flat Washer (5/16")	1	39 Z02 203
21.	Lock Washer (5/16")	1	39 Z02 204
22.	Acorn Nut (5/16" NC)	1	39 Z02 205

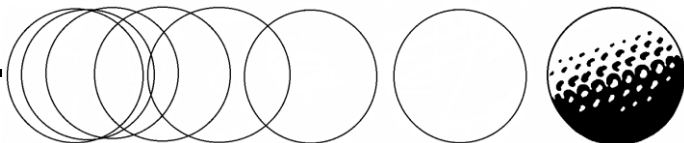
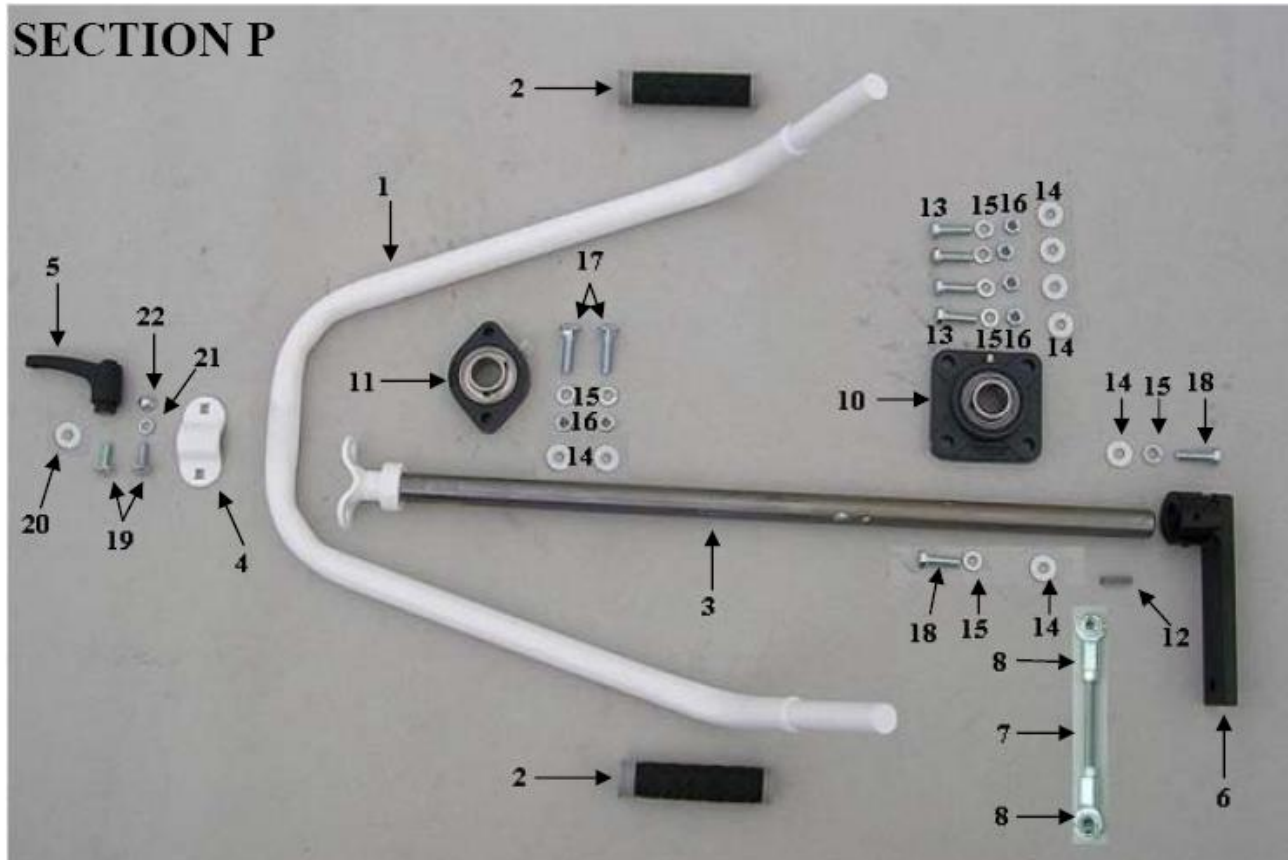

Steering Roller Components - Section Q

Item	Description	Quantity	Part #
1.	Steering Roller Frame	1	39 Q01 128
2.	Steering Roller	2	39 Q01 129
3.	Stub Axle	4	39 Q01 130
4.	Steering Roller Bearing Plate Spacer	1	39 Q01 131
5.	Flange and Bearing (4-bolt c/w 1" bearing)	1	39 Q02 132
6.	Bearing (1" c/w set screw collar)	4	39 Q02 133
7.	Pressed Flange (3-bolt)	8	39 Q02 134
8.	Snap Ring (1")	1	39 Q02 135
9.	Bolt (3/8" x 1 1/2" NC)	4	39 Z02 193
10.	Flat Washer (3/8")	8	39 Z02 195
11.	Lock Washer (3/8")	8	39 Z02 196
12.	Nut (3/8" NC)	4	39 Z02 197
13.	Bolt (5/16" x 3/4" NC)	12	39 Z02 202
14.	Flat Washer (5/16")	12	39 Z02 203
15.	Lock Washer (5/16")	12	39 Z02 204
16.	Carriage Bolt (3/8" x 1 1/2" NC)	4	39 Z02 198

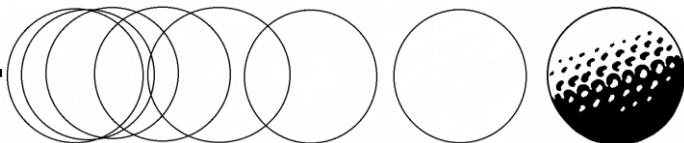
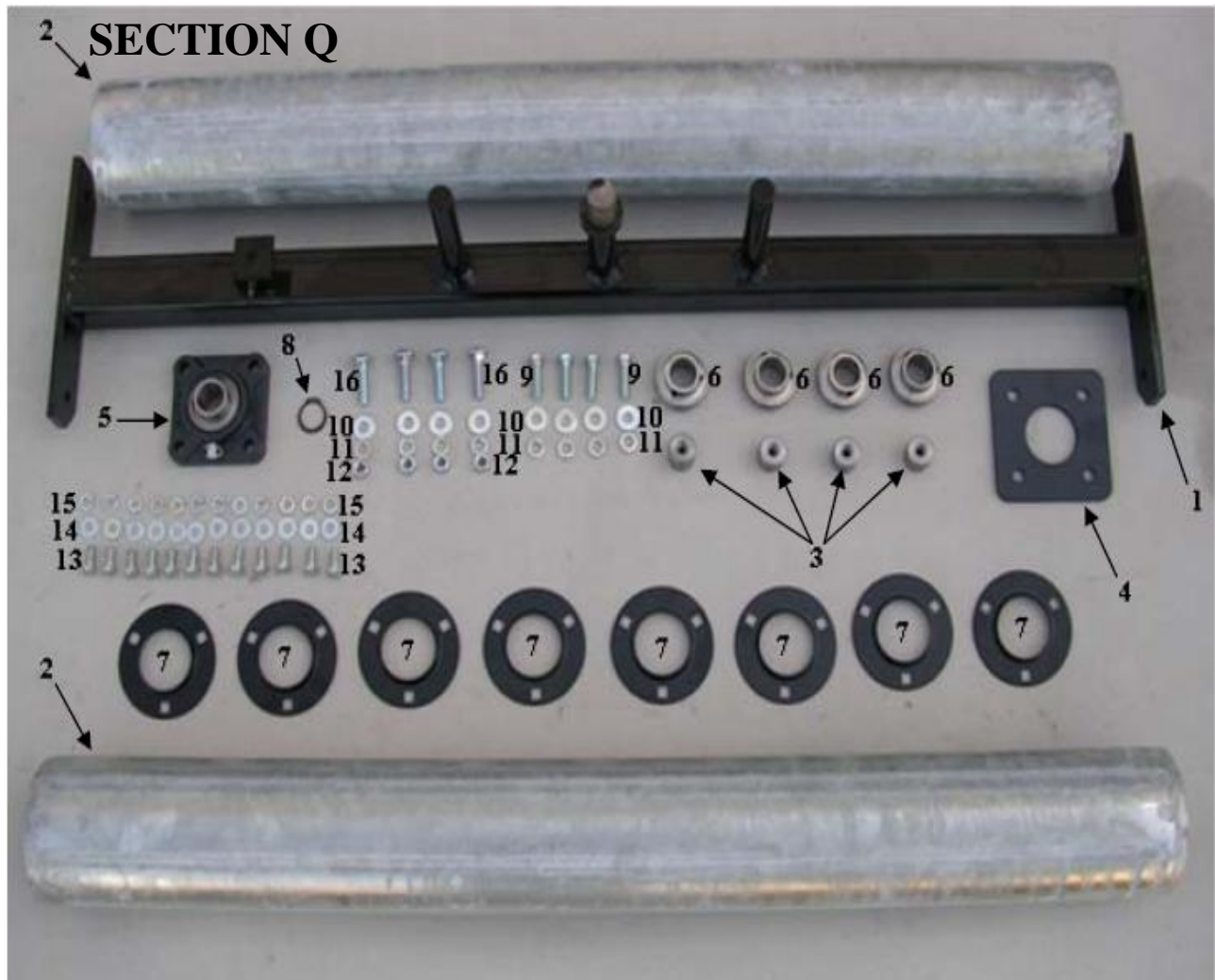

Engine Components - Section R

Item	Description	Quantity	Part #
1.	Honda 5.5 hp with Oil Alert	1	39 R02 136
2.	Motor Vibration Mount	1	39 R02 137
3.	Vibration Dampners	4	39 R02 138
4.	Digital Tach Hour/RPM Meter	1	39 R02 139
5.	Muffler Deflector and Screws	1	39 R02 140
6.	Oil Drain Assembly	1	39 R02 141
7.	Bolt (5/16" x 1 1/2" NC) secures engine to mounting plate	4	39 Z02 200
8.	Flat Washer (5/16")	8	39 Z02 203
9.	Lock Washer (5/16")	8	39 Z02 204
10.	Nut (5/16" NC)	8	39 Z02 206
11.	Carriage Bolt (5/16" x 5/8" NC)	4	39 Z02 209
12.	Electric Start Kit - All Components (Not Shown)	1	39 R02 253
13.	Electric Start Honda Engine (Not Shown)	1	39 R02 254
14.	Wiring Harness (Not Shown)	1	39 R02 255
15.	Lights (Not Shown)	2	39 R02 256
16.	Switch (Not Shown)	1	39 R02 257
17.	Battery (Not Shown)	1	39 R02 258
18.	Battery Box (Not Shown)	1	39 R02 259

SECTION R

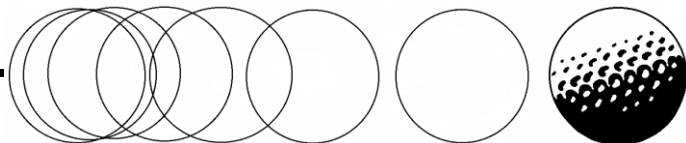

SECTION 8 (con't)**Transmission Components - Section S**

Item	Description	Quantity	Part #
1.	Chain Coupler Hub (#40 16 3/4" - Engine Side)	1	39 S02 142
2.	Chain Coupler Hub (#40 16 5/8" - Pump Side)	1	39 S02 143
3.	Key (3/16" x 1 1/4")	2	39 Y02 187
4.	Chain (#40 double)	1	39 S02 144
5.	Chain Connector	1	39 S02 145
6.	Martin Chain Cover (Includes: 2 O-rings, 4 bolts, 2 lock washers, 2 gaskets)	1	39 S02 146
7.	Hydrostatic Transmission Mounting Bracket	1	39 S01 147
8.	Hydro-Gear 10 cc Piston Pump	1	39 S02 148
9.	Hydraulic Motor Mount	1	39 S01 149
10.	Hydraulic Motor c/w woodruff key (1/4" x 1.0")	1	39 S02 150
11.	Reservoir (oil tank)	1	39 S01 151
12.	Reservoir Breather Cap	1	39 S02 152
13.	Sight Glass	1	39 S02 153
14.	Filter head	1	39 S02 154
15.	Filter (25 micron)	1	39 S02 155
16.	90° Bent Stern 1/2" Fitting	5	39 S02 156
17.	60° Bent Stern 1/2" Fitting	1	39 S02 157
18.	Hose Clamps (to fit 1/2" suction hose)	6	39 S02 158
19.	Reservoir 1/2" Drain Plug	1	39 S02 159
20.	Suction Hose (1/2" x 6.0")	1	39 S02 160
21.	Suction Hose (1/2" x 4.0")	1	39 S02 161
22.	Return Hose (1/2" x 12.0")	1	39 S02 162
23.	Pressure Hose (1/2" x 10.0")	2	39 S02 163
24.	ORB Adaptor (hydraulic motor to pressure hose)	2	39 S02 164
25.	ORB Adaptor (hydrostatic transmission to pressure hose)	2	39 S02 165
26.	Transmission Cover (Not Shown)	1	39 S01 166
27.	Rubber Catch (Not Shown)	2	39 S02 167
28.	Engagement Arm	1	39 S01 168
29.	Transmission Engagement Rod (5/16" x 5.0" NF)	1	39 S01 169
30.	Rod End (5/16" - Female RH)	2	39 S02 170
31.	AVM Dampner	1	39 S02 171
32.	Neutral Return Spring	1	39 S02 172
33.	Bolt (1/2" x 1 1/2" NC)	2	39 Z02 189
34.	Lock Washer (1/2")	2	39 Z02 191
35.	Nut (1/2" NC)	2	39 Z02 192
36.	Bolt (3/8" x 1 1/2" NC)	2	39 Z02 193
37.	Flat Washer (3/8")	6	39 Z02 195
38.	Lock Washer (3/8")	6	39 Z02 196
39.	Nut (3/8" NC)	8	39 Z02 197

SECTION 8 (con't)

40.	Carriage Bolt (3/8" x 1 1/4" NC)	4	39 Z02 199
41.	Bolt (5/16" x 1" NC)	5	39 Z02 201
42.	Flat Washer (5/16")	3	39 Z02 203
43.	Lock Washer (5/16")	7	39 Z02 204
44.	Nut (5/16" NC)	5	39 Z02 206
45.	Nut (5/16" NF)	2	39 Z02 207
46.	Bolt (1/4" x 3/4" NC)	2	39 Z02 210
47.	Flat Washer (1/4")	2	39 Z02 211
48.	Lock Washer (1/4")	2	39 Z02 212
49.	Nut (8mm)	2	39 Z02 213

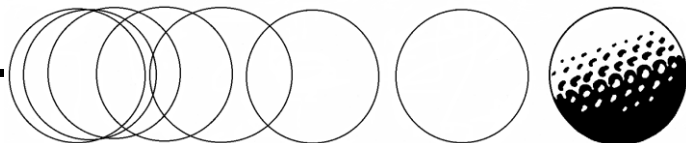

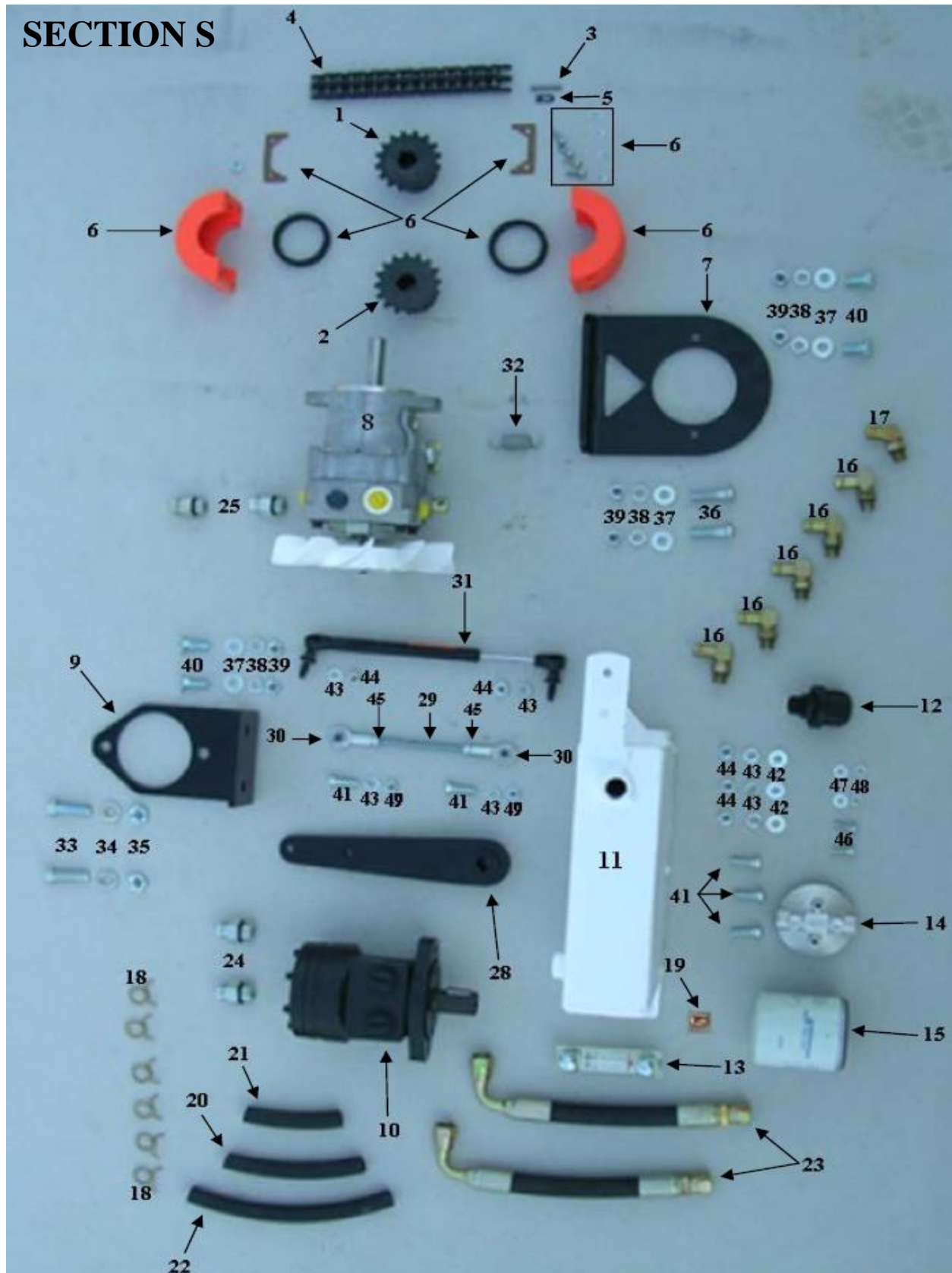

Main Drive Components - Section W

Item	Description	Quantity	Part #
1.	Transmission Sprocket (#50 23T - 1.0" Bore)	1	39 W02 173
2.	Drive Chain (#50 39")	1	39 W02 174
3.	Drive Chain Connector #50	1	39 W02 175
4.	Idler Sprocket (#50 13T 1/2" Bore)	1	39 W02 176
5.	Chain Adjuster Bracket	1	39 W01 177
6.	Bolt (1/2" x 2.5" NC)	1	39 Z02 188
7.	Flat Washer (1/2")	3	39 Z02 190
8.	Lock Washer (1/2")	2	39 Z02 191
9.	Nut (1/2" NC)	1	39 Z02 192
10.	Carriage Bolt (3/8" x 1 1/4" NC)	2	39 Z02 199
11.	Flat Washer (3/8")	2	39 Z02 195
12.	Lock Washer (3/8")	2	39 Z02 196
13.	Nut (3/8" NC)	2	39 Z02 197

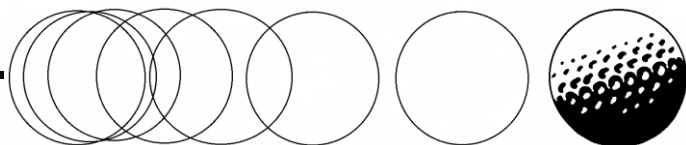
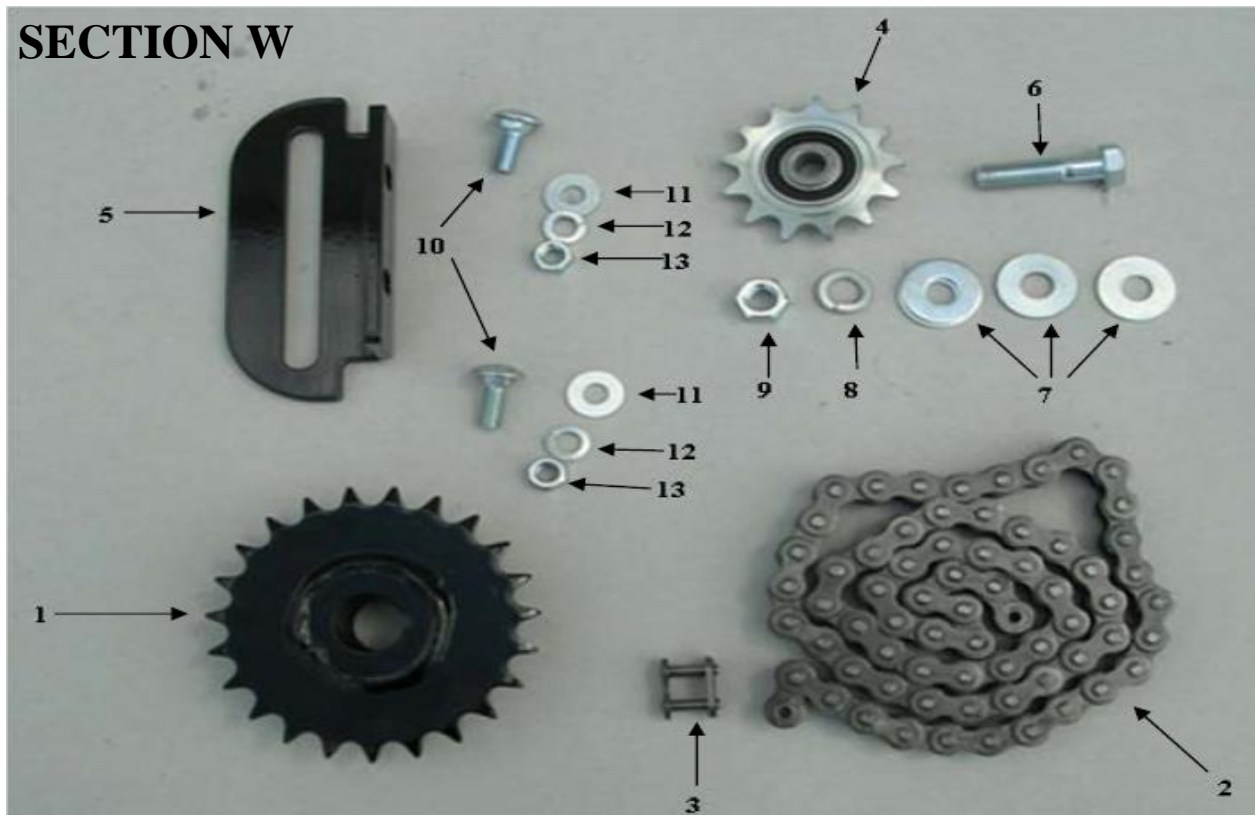

SECTION 8 (con't)

Drive Roller Components - Section X

Item	Description	Quantity	Part #
1.	Drive Roller*	1	39 X01 178
2.	Sprocket (#50 23T)	1	39 X02 180
3.	Bearing and Housing (2-bolt PB 1.0")	2	39 X02 181
4.	Key (1/4" x 1/4" x 1 1/4")	1	39 X02 182
5.	Bolt (3/8" x 1 1/2" NC)	4	39 Z02 193
6.	Flat Washer (3/8")	8	39 Z02 195
7.	Lock Washer (3/8")	4	39 Z02 196
8.	Nut (3/8" NC)	4	39 Z02 197
9.	Glue & Covering Assembly <ul style="list-style-type: none">• CAN BE ORDERED SEPARATELY – SEE BELOW	1	39 X01 179
10.	Pebble Top Roll Covering	1	39 X01 273
11.	Glue & Hardner	1	39 X01 274

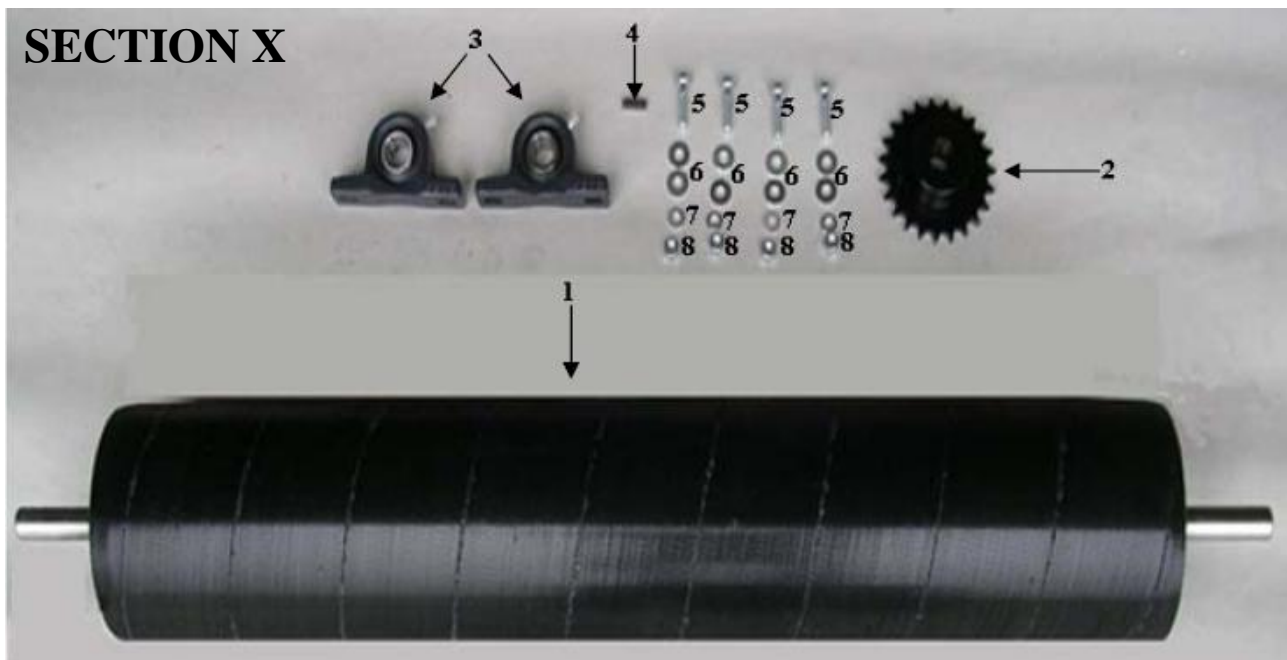

SECTION 8 (con't)

Trailer Components - Section TT

Item	Description	Quantity	Part #
1.	Trailer Complete	1	39 TT01 218
2.	Trailer Body	1	39 TT01 219
3.	Trailer Tail Gate	1	39 TT01 220
4.	Tow Bar	1	39 TT01 221
5.	Tail Gate Latch	2	39 TT01 222
6.	Safety Latch Locking Pin	1	39 TT01 223
7.	Hinge Pin (for Tail Gate)	2	39 TT01 224
8.	Tail Gate Latch Mount	2	39 TT01 225
9.	Return Spring (for Tail Gate Latch)	2	39 TT02 226
10.	Trailer Clevis	1	39 TT01 227
11.	Cotter Pin (5/32" x 1 1/2")	1	39 TT02 228
12.	Cotter Pin (1/8" x 1.0")	2	39 TT02 229
13.	Fender	2	39 TT01 230
14.	Axle Support c/w Spindle	2	39 TT01 231
15.	Hub	2	39 TT02 232
16.	Rim (for Tire 18 x 8.50)	2	39 TT02 233
17.	Tire (18 x 8.50)	2	39 TT02 234
18.	Wheel Nut	8	39 TT02 235
19.	Dust Cap	2	39 TT02 236
20.	Tapered Bearing (1.0")	2	39 TT02 237
21.	Seal	1	39 TT02 238
22.	Bolt (1/2" x 2 3/4" NC)	6	39 Z02 214
23.	Nut (1/2" NC)	6	39 Z02 192
24.	Flat Washer (1/2")	12	39 Z02 190
25.	Lock Washer (1/2")	6	39 Z02 191
26.	Lock Nut (3/4" NC)	1	39 Z02 215
27.	Flat Washer (3/4")	1	39 Z02 216
28.	Nylon Lock Nut (3/8" NC)	2	39 Z02 217
29.	Flat Washer (3/8")	4	39 Z02 195
30.	Jam Nut (9/16")	1	39 TT02 239
31.	Curved Pin Striping (L & R) Decal (Not Shown)	2	39 TT02 240
32.	Caution Keep Hands Clear Decal (Not Shown)	1	39 TT02 241
33.	Caution Hook Up Trailer Before Unloading Decal (Not Shown)	1	39 TT02 242
34.	3900 Decal (Not Shown)	1	39 TT02 243
35.	3900 Tailgate Decal (Transparent) and (Not Shown)	1	39 TT02 244

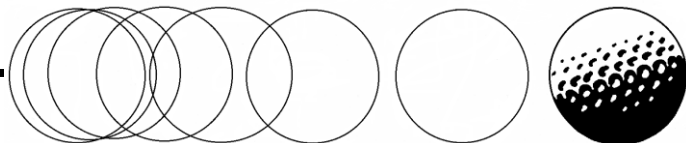

SECTION TT

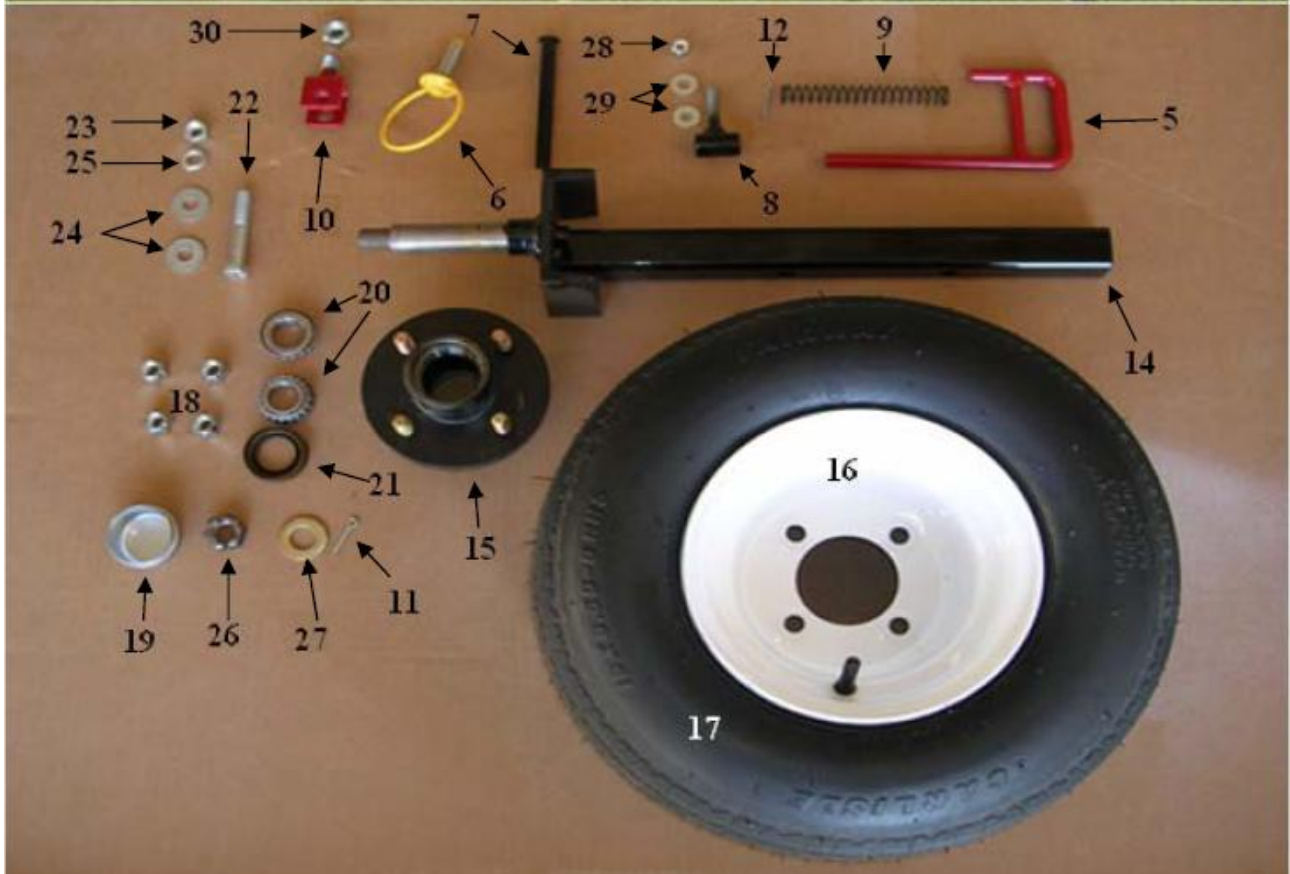
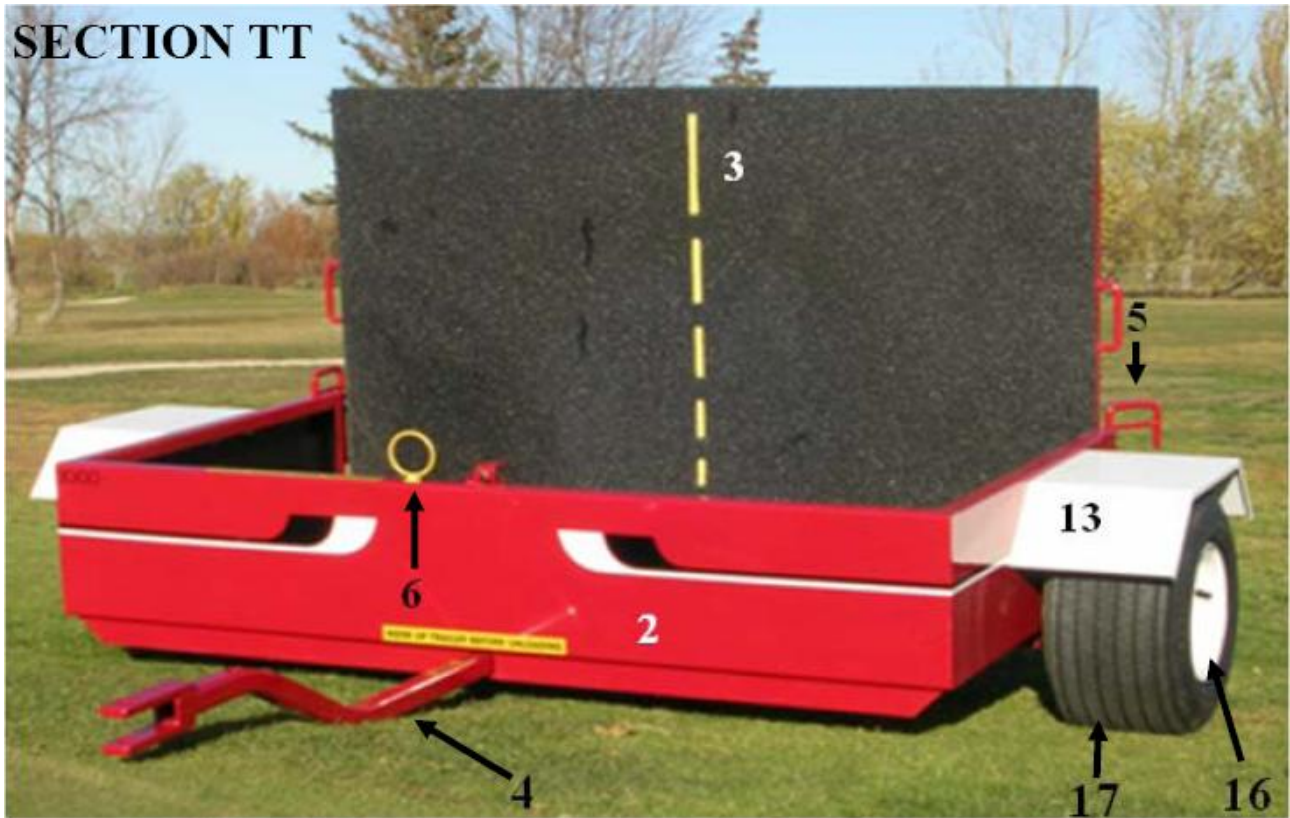

SECTION 8 (con't)

Item	Description	Quantity	Part Number
Turf Broom Components—Section T			
	Turf Broom Package – Complete	1	30 T01 1000
39	Support Bracket—Right	1	30 V02 2680
40	Support Bracket—Left	1	30 V02 2690
41	Turf Broom Weight Bar	1	30 T22 5880
42	Broom – 2” x 3 feet	3	30 T13 6290
43	Wheel, caster with bearing	2	30 T08 6600
	Decal – Turf Broom	1	30 T02 275
	Support Bolts, ½” x 1”	4	WB 8175
	Washer, ½”	4	WB 8770
Turf Ventilator Components—Section V			
	Turf Ventilator – Complete	1	30 V01 1000
44	Support Bracket—Right	1	30 V02 2680
45	Support Bracket—Left	1	30 V02 2690
46	Weight Bar and Handle Assembly	1	30 V05 2740
	Shaft for Ventilator (Hexagonal)—not illustrated	1	30 V06 2750
47	Turf Venting Blades	30	30 V06 2760
48	Spacers Between Blades	29	30 V06 2770
49	Spacers, Nylon for Outside Ends	2	30 V06 2780
50	Bearing and Housing (2-bolt pillow block)	2	WB 7360
	Decal – Turf Ventilator	1	30 V02 276
	Support Bolts, ½” x 1” NC	4	WB 8175
	Lock Washer, ½”	4	WB 8770

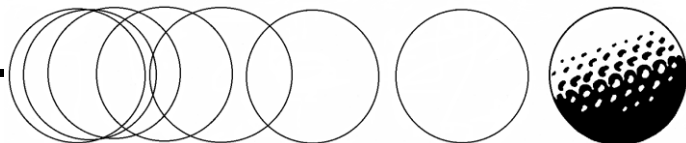
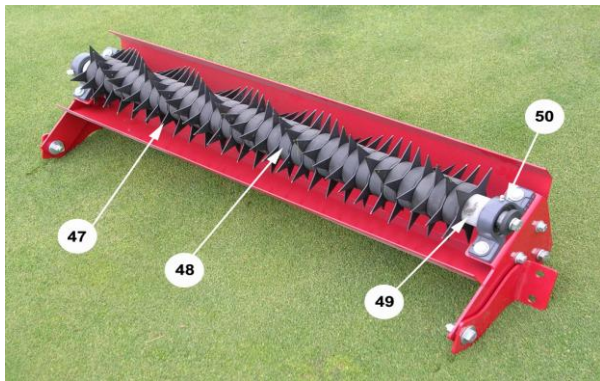
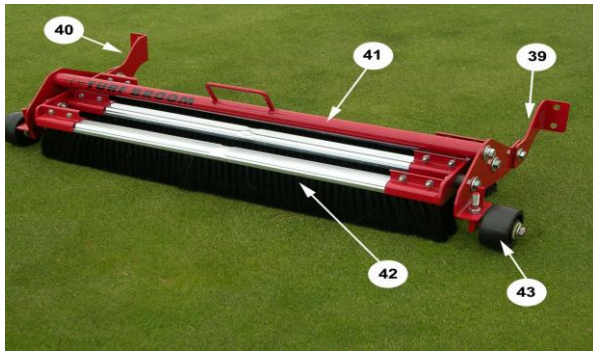

SECTION 8 (con't)

Light Kit Components - Section LK

Item	Description	Quantity	Part #
1.	25 Watt Lights	2	39 LK02 246
2.	Fly Wheel	1	39 LK02 247
3.	25 Watt Coil (10.5")	1	39 LK02 248
4.	25 Watt Coil (12")	1	39 LK02 249
5.	Wiring Harness (12")	1	39 LK02 250
6.	Wiring Harness (36")	1	39 LK02 251
7.	Switch	1	39 LK02 252
8.	Bolt (6mm x 30mm)	4	39 Z02 245
9.	Light Kit Complete	1	39 LK01 253

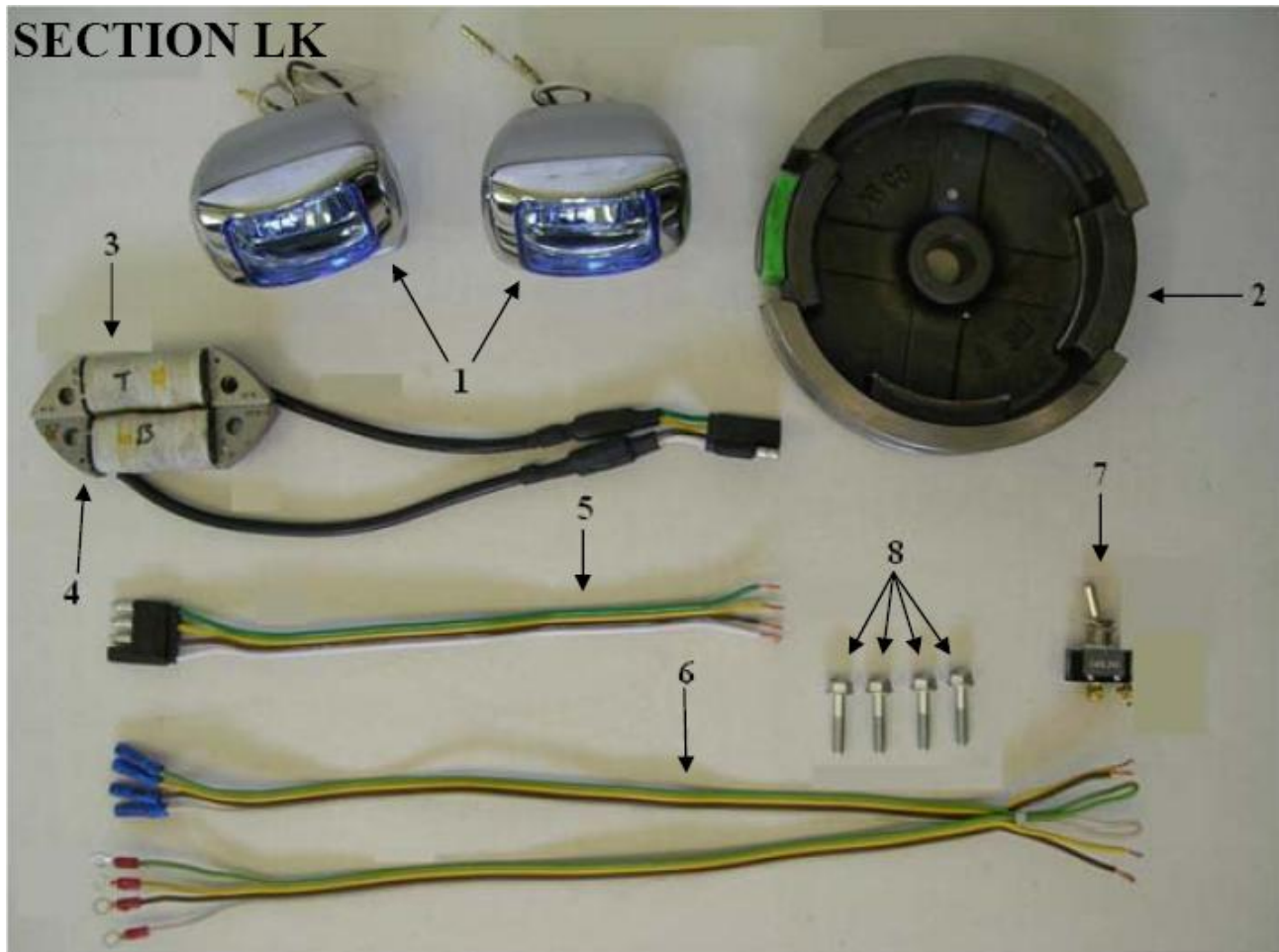

Warranty

greensIRON 3900

WARRANTY is provided as part of Wood Bay's support program for customers who operate and maintain their equipment as described in this manual and other enclosed owner's manuals.

This warranty provides you with the assurance that Wood Bay will back this product where defects appear within the warranty period. Should the product be abused or modified to change its performance from original factory specifications, the warranty will become void.

If you have any questions...

Wood Bay Distributors are very interested in your complete satisfaction with the performance of your *greensIRON 3900*. In the event of a warranty or related servicing matter, we encourage you to contact your local distributor as soon as possible. Should the warranty or servicing problem not be resolved to your satisfaction, submit the matter to:

Wood Bay Turf Technologies

Toll free: 1-800-661-4942 (USA, Canada and Mexico)

Or call: 1-780-468-4378 (USA, Canada, Mexico and International)

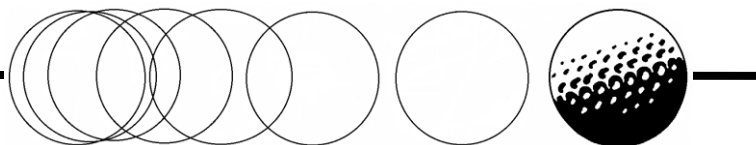

SECTION 9 (con't)

A. GENERAL PROVISIONS

For the first twelve (12) months after the date of purchase, the manufacturer will repair or replace, as it elects, any part(s) defective in material or workmanship (except those specified in Sections B and C below) of a new *greensIRON 3900* Turf Roller and/or Turf Broom and/or Turf Ventilator (the "Product"), as delivered to the original retail purchaser. This warranty applies only to purchases from authorized distributors and extends only to the original retail purchaser of the product.

The performance of this warranty is dependant on receipt by Wood Bay Turf Technologies or Wood Bay Consulting Group Limited (hereinafter referred to as the "manufacturer") of the warranty registration card from the original retail purchaser.

B. ITEMS WARRANTED SEPARATELY

This warranty does not apply to the Honda Motor, the Hydro-Gear hydrostatic pump, or the hydraulic motor, which are all covered by separate written warranties.

C. ITEMS NOT COVERED

The manufacturer is not responsible for the following:

1. Premium charged for overtime labor requested by the purchaser.
2. Transportation to and from the distributor's office or service calls made by the distributor.
3. Used products.
4. Modification of any component or part of the product not supplied by the manufacturer or not performed on by the manufacturer or by an authorized distributor.
5. Depreciation or damage caused by normal wear, lack of reasonable and proper maintenance, failure to follow operating instructions, misuse, lack of proper protection during storage, or accident.
6. Normal maintenance and replacement of maintenance wear items, such as oil filters, chain, sprockets, bearings, drive roller covering and tires.

D. PARTS REPLACED UNDER WARRANTY

Only new or remanufactured parts or components furnished or approved by the manufacturer, will be used to repair the product.

E. SECURING WARRANTY SERVICE

To obtain performance of this warranty, the original retail purchaser must request warranty service from an authorized distributor. Present evidence that corresponds with the warranty registration card on date of delivery, and inform the distributor in what way the purchaser believes the product to be defective.

F. NO IMPLIED WARRANTY OR OTHER REPRESENTATION

Where permitted by law, neither the manufacturer nor any company affiliated with the manufacturer makes warranties, representations or promises as to the quality, performance or freedom from defect of the product covered by this warranty. **NO IMPLIED WARRANTY OF MERCHANTABILITY OF FITNESS IS MADE.**

SECTION 9 (con't)

G. LIMITATION OF PURCHASER'S REMEDIES

Where permitted by law, the purchaser's only remedies in connection with the breach or performance of any warranty on the product are those set forth on this page. In no event will the distributor, manufacturer or any company affiliated with the manufacturer be liable for incidental or consequential damages, including but not limited to loss of profit, rental of substitute equipment or other commercial loss.

H. NO SUBDISTRIBUTOR OR DISTRIBUTOR WARRANTY

The selling distributor makes no warranty of its own on any item warranted by the manufacturer and makes no warranty on any other item unless it delivers to the purchaser a separate written certificate specifically warranting the item. **THE DISTRIBUTOR HAS NO AUTHORITY TO MAKE ANY REPRESENTATION OR PROMISE ON BEHALF OF THE MANUFACTURER, OR TO MODIFY THE TERMS OR LIMITATIONS OF THIS WARRANTY IN ANY PART.**

CUSTOMER RECORD COPIES TO REMAIN IN MANUAL

WARRANTY REGISTRATION DETAILS (Please print clearly)			
Purchase Date:	_____		
Owner:	_____		
Address:	_____		
City:	State/Province:	Code:	
Model No.:	Serial No.:		_____
Engine No.:	Transmission No.:		_____
Selling Distributor:	_____		
Pre-Delivery Certification:	_____		
	(Distributor Signature)		
			Customer Copy

SAFETY ACKNOWLEDGEMENT	
I, _____ acknowledge reading all pertinent safety and operational information enclosed and that the distributor has advised me of the locations and the reasons for all safety emblems on the machine. The distributor has also advised me on the safe operating procedures for the <i>greensIRON 3900</i> . This information will be made available to all other operators of the <i>greensIRON 3900</i> .	
_____	Date: _____
(Superintendent)	
	Customer Copy

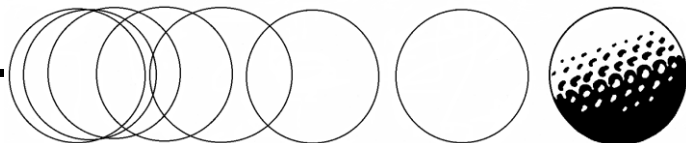

This page left intentionally blank

SECTION 9 (con't)

DISTRIBUTOR COPY - TO BE COMPLETED AND REMOVED AT POINT OF SALE

WARRANTY REGISTRATION DETAILS
(Please print clearly)

Purchase Date: _____
Owner: _____
Address: _____
City: _____ State/Province: _____ Code: _____
Model No.: _____ Serial No.: _____
Engine No.: _____ Transmission No.: _____
Selling Distributor: _____
Pre-Delivery Certification: _____
(Distributor Signature) Distributor Copy

WOOD BAY COPY - TO BE COMPLETED, REMOVED AND FORWARDED TO:

Wood Bay Turf Technologies
A Division of Wood Bay Consulting Group Limited
202, 8704 – 51 Avenue
Edmonton, Alberta T6E 5E8

WARRANTY REGISTRATION DETAILS
(Please print clearly)

Purchase Date: _____
Owner: _____
Address: _____
City: _____ State/Province: _____ Code: _____
Model No.: _____ Serial No.: _____
Engine No.: _____ Transmission No.: _____
Selling Distributor: _____
Pre-Delivery Certification: _____
(Distributor Signature) Wood Bay Copy

SAFETY ACKNOWLEDGEMENT

I, _____ acknowledge reading all pertinent safety and operational information enclosed and that the distributor has advised me of the locations and the reasons for all safety emblems on the machine. The distributor has also advised me on the safe operating procedures for the *greensIRON 3900*. This information will be made available to all other operators of the *greensIRON 3900*.

_____ Date: _____
(Superintendent) Wood Bay Copy

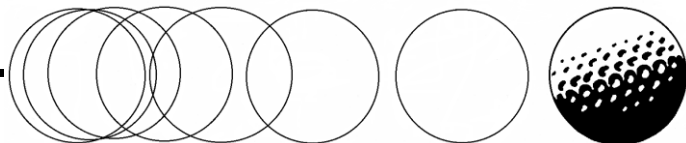

This page left intentionally blank

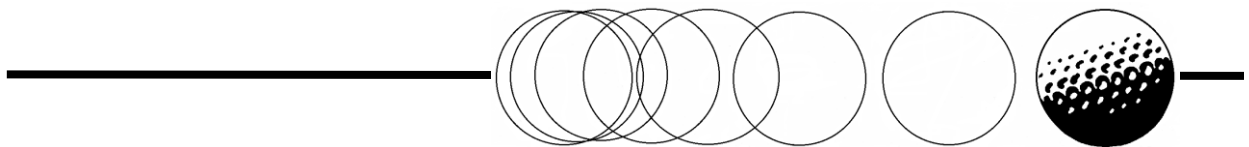



greensIRON **3900**

MANUFACTURED BY:



Turf Technologies

FOR LOCAL SALES & SERVICE INFORMATION CALL:

202 - 8704 51 Ave.
Edmonton, Alberta
Canada T6E 5E8

Toll Free: 1-800-661-4942

Direct: 1-780-468-4378

E-mail: info@woodbayturftech.com

Web Site: www.woodbayturftech.com

